



# Activity Report 2018

Team GRANIT

Adaptive Algorithms and Architectures  
for Energy-efficient Wireless Systems

D3 – Architecture





## 1 Team

Name	Forename	Position
BERDER	Olivier	Full Professor, UR1 (IUT Lannion)
CARER	Arnaud	Research Engineer <sup>+</sup> , UR1
CARQUIN	Émilie	Research Assistant, UR1 (ENSSAT Lannion)
COURTAY	Antoine	Associate Professor, UR1 (ENSSAT Lannion)
DEMIGNY	Didier	Full Professor*, UR1 (IUT Lannion)
GAUTIER	Matthieu	Associate Professor, UR1 (IUT Lannion)
GERZAGUET	Robin	Associate Professor, UR1 (ENSSAT Lannion)
ROCHER	Romuald	Associate Professor, UR1 (IUT Lannion)
SCALART	Pascal	Full Professor, UR1 (ENSSAT Lannion)
THÉPAULT	Joëlle	Research Assistant, UR1 (ENSSAT Lannion)
VRIGNEAU	Baptiste	Associate Professor, UR1 (IUT Lannion)

<sup>+</sup> Shared with CAIRN team

\* Associate member

Table 1: GRANIT permanent members

The GRANIT team comprizes 8 permanent members: 2 full professors (*Professeur des Universités*), 5 associate professors (*Maître de conférences*) and one research engineer (shared with CAIRN Team<sup>1</sup>). There are currently 6 full time PhD students in the GRANIT team, while 3 others are co-supervised with the CAIRN team. Table 1 lists the permanent staff and table 2 the current PhD students and other staff.

Didier DEMIGNY is considered as an associate member of GRANIT since he still has a research activity with some of GRANIT members, but its administrative and teaching tasks are very time consuming. Didier Demigny was director of the Institute of Technology of Lannion and is now vice-president of University of Rennes 1.

## 2 Overall Objectives

### 2.1 Overview

General purpose wireless devices as smartphones already have to carry more and more data while keeping their autonomy as long as possible, but the next challenge they will face is the ubiquity of users. This ability to be connected everywhere in a continuous and transparent way, keeping the same quality of services (QoS) whatever the environment, implies that devices can deal with different wireless standards, furthermore choosing for each of them the most energy efficient configuration. In this connected world, even the smallest sensors will be able to send their data over what is called Internet of Things (IoT), such that every user in the world could

---

<sup>1</sup>As both GRANIT and CAIRN teams are located at ENSSAT Lannion and belong to D3 department of IRISA (they were formerly a unique team, split in 2015), they have a common development unit

Name	Forename	Status	Period
DJIDI	Nour el hoda	PhD	Since 10/2018
GLEONEC	Philip Dylan	PhD	Since 10/2015
KAZDOGHLI LAGHA	Marwa	PhD	Since 10/2017
LACROIX	Marie-Anne	PhD	Since 10/2018
LAVAUD	Corentin	PhD	Since 10/2018
ROUX	Nicolas	PhD <sup>+</sup>	Since 10/2016
TRAN	Mai Thanh	PhD <sup>+</sup>	10/2013 - 10/2018
DIALLO	Mamadou Lamarana	Post-doc	Since 01/2018
LE	Xuan-Chien	Post-doc	05/2017 - 05/2018
LE GENTIL	Mickaël	Research Engineer	Since 09/2016
MABON	Malo	Research Engineer	Since 01/2018

<sup>+</sup> Shared with CAIRN team

Table 2: GRANIT other staff

reach it. The problem that designers will face is then the autonomy of such sensors, since radio is very energy consuming, and obviously, the more sensors we place, the less we want to change batteries.

### Energy autonomous Communications

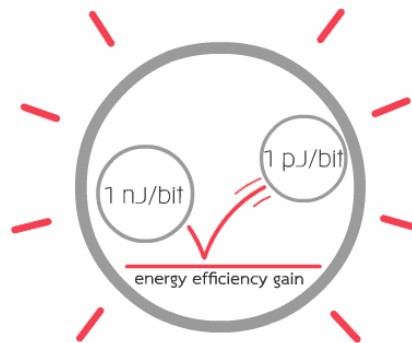

Figure 1: Transmission Energy efficiency target for the next decade

In such a context, the GRANIT team purpose is to design algorithms and architectures able to adapt to environment parameters, such as propagation channel characteristics, wireless traffic conditions network topology or possibilities of energy harvesting, while respecting applications requirements in terms of data rate, reliability, latency, and most of all, life time of involved systems, etc. As represented by Fig. 1, the quantitative target of GRANIT over the next ten years is to decrease the energy of radio transmission by several orders of magnitude to reach 1 pJ per bit. The GRANIT members have a strong experience on wireless sensor network (WSN) protocols (MAC and PHY layers) and hardware architectures, and de-

veloped several WSN platforms and demonstrators for various areas monitoring applications or dedicated to human body. As energy can now be scavenged from the direct environment of sensor nodes (light, heat, vibrations, etc.), a harvesting board can be added to WSN platforms. One of the objectives of the GRANIT team is then to design power management strategies, coupled to above-mentioned adaptive algorithms in order to reach real energy autonomy of the sensor nodes. Cooperation between nodes, either through distributed computing to find the best radio/computation trade-off or through the choice of the best cooperative relaying schemes, represents also a key challenge for the design of energy-efficient wireless systems. The GRANIT team will continue to investigate this very promising field at both physical and medium access layers. Last but not least, the aim of GRANIT team is also to efficiently implement these algorithms onto different targets, from low power microcontrollers and/or low power FPGAs for WSN solutions to powerful system-on-chip and multi-core systems for more computing-intensive applications. To answer the demand of agile devices, software defined radio solutions (SDR) will especially be considered, not only for high data-rate mobile standards such as 5G, but also for wireless sensor networks, enabling testbeds for low power adaptive and/or cooperative solutions.

## 2.2 Key Issues

Wireless communications represent obviously the major domain of applications for the adaptive algorithms and/or architectures proposed by the GRANIT team. The range of devices that fall within this denomination is however very large, and our developments will mainly address two different targets, namely next generations of wireless systems (4G, 5G, . . .) and wireless sensor networks. In addition to analytical derivations and simulations, the GRANIT team clearly aims at using platforms to evaluate our research performance, but also to reach what could be called a platform-based design, meaning that the constraints of the envisaged platforms are taken into account very soon in the design process. Upon this basis, the research topics of the GRANIT team can be represented as Figure 2.

Focusing on the baseband processing of the physical layer, two main issues are raised by the new requirements of wireless communications: (i) What are the signal processing techniques that could help improving the link quality, the spectrum usage and the energy efficiency? (ii) What kind of hardware could associate energy efficiency and high-performance computing of these signal processing techniques? A huge effort is currently spent on proposing new physical layers and many digital communication techniques have been widely studied.

Taking into account the specificities of the targets envisaged for the adaptive algorithms, we will adapt the latter to design very energy-efficient wireless transmissions. To a certain degree, we claim that software-based systems will provide the flexibility to adapt to new requirements and make it easier to introduce innovation in the architecture<sup>2</sup>. Thus, our proposal relies on high-level synthesis (HLS) in order to bridge the gap between high-level specifications and hardware implementation<sup>3</sup>. Depending on the hardware target, hardware/software

---

<sup>2</sup>J.F. Jondral, Software-defined radio: basics and evolution to cognitive radio. *EURASIP J. Wireless Commun. Netw.*, 2005, pp. 275-283

<sup>3</sup>P. Coussy, D. Gajski, M. Meredith, A. Takach, An Introduction to High-Level Synthesis, *IEEE Design & Test of Computers*, 26 (4): 8-17, 2009

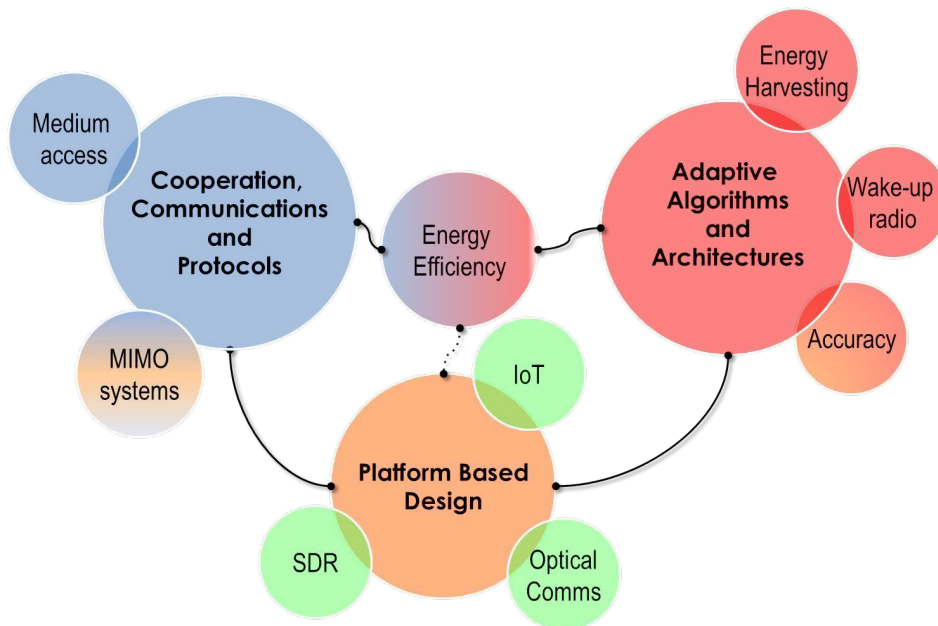

Figure 2: GRANIT Research Topics

partitioning, reconfiguration capability or power management will be included in the design flow.

### 3 Scientific Foundations

#### 3.1 Positioning in Architecture Department of IRISA

GRANIT belongs to D3 department of IRISA dedicated to Architecture and takes place besides PACAP and CAIRN teams. While these latter teams aim to design new architectures and associated compiling tools, the approach of GRANIT is more user or application-centric, i.e. our research will mostly rely on existing hardware platforms (even though some specific designs will still be achieved) and take into account the constraints that they incur to develop efficient algorithms. This interaction between architecture and algorithms is explored from both angles of adaptivity and cooperation.

#### 3.2 Adaptive algorithms and architectures

One of the purposes of the GRANIT team is to consider algorithmic-level optimizations for energy savings. More precisely, the relationship between computation and communication will be studied from the energy point of view, in order to enable dynamic energy management. Reducing power due to radio communications can be achieved by two complementary main objectives: (i) to minimize the output transmit power while maintaining sufficient wireless link quality and (ii) to minimize useless wake-up and channel hearing while still being reactive. For

this purpose, this project aims at defining and implementing new power-aware techniques that can dynamically adapt at run-time:

- the chosen algorithms of the radio physical layer (e.g. modulation, spreading, bit-rate, cooperative strategies, etc.),
- the wake-up interval of the MAC protocol,
- the accuracy (bit-width) of signal processing algorithms,
- the transmit power,

depending on some parameters such as:

- radio channel conditions,
- quality-of-service (QoS) required by the application,
- harvested energy,
- topology of the networks.

The global framework of such an optimization can be represented as in Figure 3.

**Energy harvesting and Power Management** Advancements in renewable energy sources, such as solar, thermal or wind, are increasing the attention in autonomous Wireless Sensor Networks (WSN). Everlasting energy harvesting allows long-term operations of wireless nodes, which can extremely reduce the cost of battery charging or replacement. Moreover, it has opened a new paradigm for designing Power Managers in self-powered autonomous nodes. Instead of minimizing the consumed energy to maximize the system lifetime as in battery-powered nodes, the PM dynamically adapts the consumed energy according to the fluctuations of the harvested energy, leading to Energy Neutral Operation (ENO)<sup>4</sup>.

The GRANIT team activities in EH-WSN aim at designing and implementing new PM (Fig. 4) able to deal with the environment constraints and ensure ENO by tuning sensing, processing and communication parameters.

**Software Defined Radio** Software Defined Radio (SDR) is a flexible signal processing architecture with reconfiguration capabilities that can adapt itself to various air-interfaces. It was first introduced by <sup>5</sup> as an underlying structure for Cognitive Radio (CR). The FPGA (Field Programmable Gate Array) technology is expected to play a key role in the development of Software Defined Radio (SDR) platforms. FPGA-based SDR is a quite old paradigm and we are fronting this challenge while leveraging the nascent High Level Synthesis tools and

---

<sup>4</sup>A. Kansal, J. Hsu, S. Zahedi, and M. B. Srivastava, Power management in energy harvesting sensor networks, *ACM Trans. Embed. Comput. Syst.*, vol. 6, no. 4, Sep. 2007

<sup>5</sup>Joseph Mitola J. Mitola III and G. Q. Maguire, Jr., Cognitive radio: making software radios more personal, *IEEE Personal Communications Magazine*, vol. 6, nr. 4, pp. 13-18, Aug. 1999

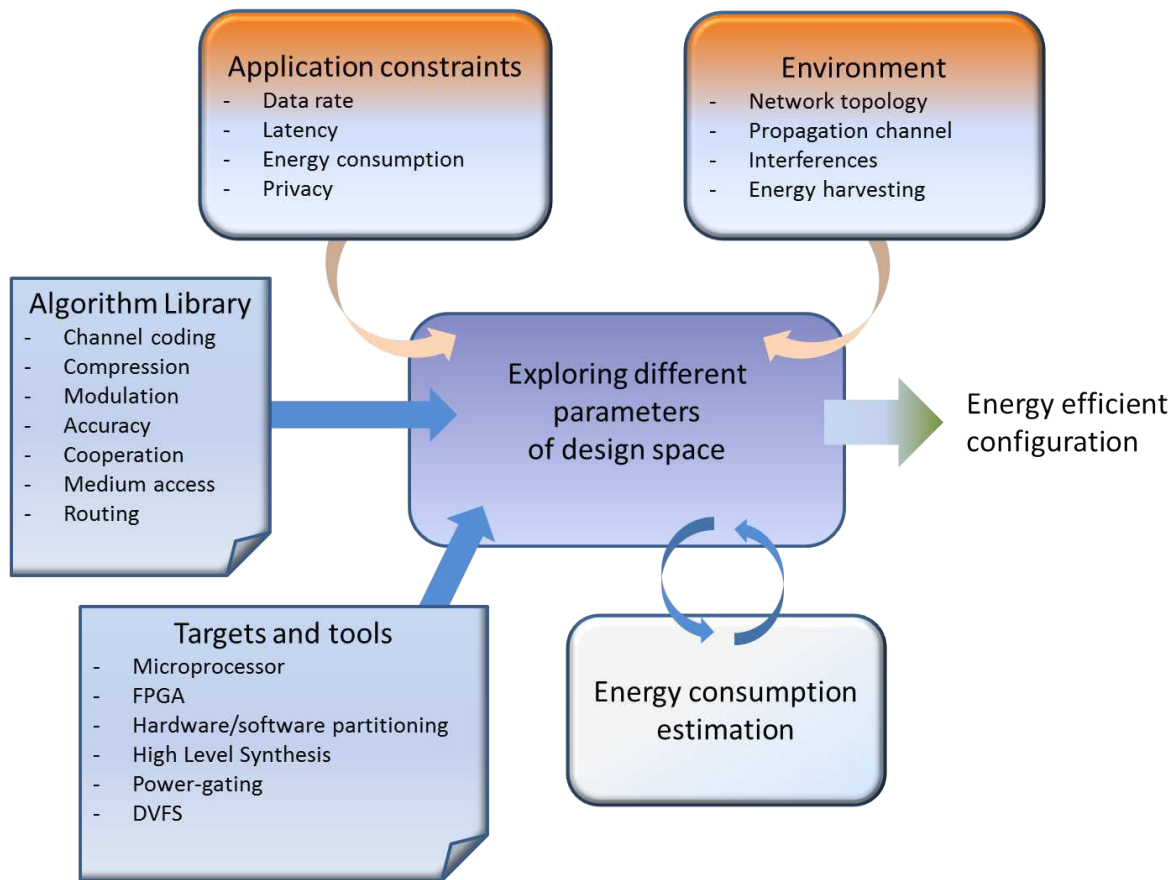

Figure 3: GRANIT Optimization Methodology

languages. Actually, our goal is to propose methods and tools for rapid implementation of new waveforms in the stringent flexibility paradigm. We propose a novel design flow for FPGA-based SDR applications. This flow relies upon HLS principles and its entry point is a Domain-Specific Language (DSL) which partly handles the complexity of programming an FPGA and integrates SDR features. Our studies include :

- defining a Domain-Specific Language for high-level descriptions of radio waveforms,
- generating hardware description (RTL) through the automatic synthesis of the DSL,
- including design constraints in the description through Design Space Exploration of the architecture,
- allowing Dynamic Partial Reconfiguration in the design process,
- validating the design flow from testbed with developments on the GRANIT platforms for multiple standards.



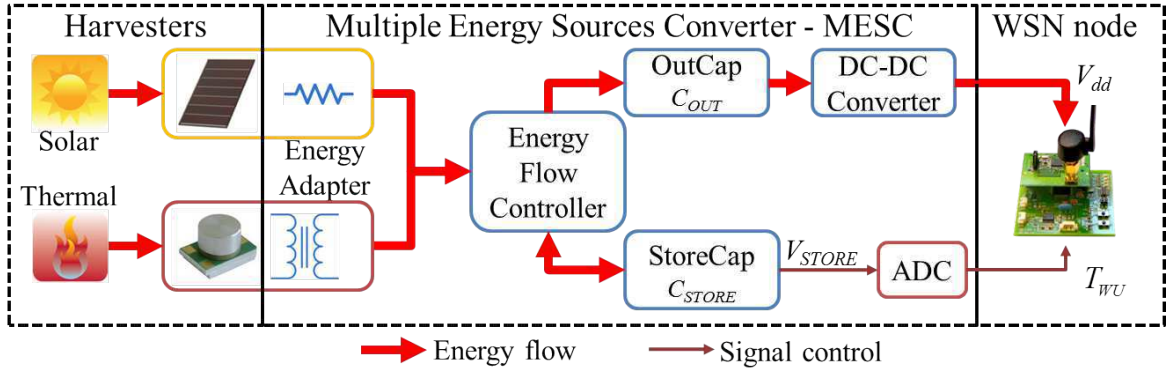

Figure 4: GRANIT Hardware Architecture of our Energy Harvesting Nodes

**Fixed point arithmetic** Fixed-point architectures manipulate data with relatively small word-lengths, which could offer the advantages of a significantly lower area, latency, and power consumption in embedded systems. However, fixed-point arithmetic introduces quantization noises which modify computation accuracy and, so, the application integrity. Our approach consists in studying fixed-point accuracy privileging analytical methods. These ones reduce drastically the conversion time compared to methods based on simulation during the floating-point arithmetic to fixed-point arithmetic conversion process of the application.

Our studies include :

- Efficient implementation of equalization and synchronous algorithms for digital applications
- Adaptive precision scaling: modifying precision according to channel and environment modifications
- Multi-constraints implementations of digital communication applications: the idea is to find a satisfying implementation according to different constraints (multi accuracy, and/or latency, and/or cost)
- Sampling frequency effects on computing accuracy
- Study of new arithmetics for digital applications (approximate computing, vectorial quantization...)

### 3.3 Cooperative Communications and Protocols

In most of wireless sensor networks, the radio in both transmit and receive modes consumes the bulk of the total power consumption of the system. The diversity achieved by cooperative communications represent a very promising opportunity to decrease the transmit power. To illustrate this statement, let us consider a Wireless Body Area Network (WBAN), where the channel conditions are very different if we consider an on-body transmission or a transmission towards a distant base station. Within the WBAN, signals will experience strong shadowing

effects due to body motion and the propagation loss is no more directly proportional to the distance between the transmitter and the receiver. In this context, the instantaneous position of the nodes can have a great impact on the link reliability and cooperative relaying schemes and opportunistic protocols are very useful to keep the same QoS without increasing the transmission power. On the other hand transmissions from the WBAN to base stations can be considered as less time-varying. Considering the possibility for nodes on-body to know the channel state information, distributed MIMO precoders can be designed in order to decrease the energy required for this kind of transmissions.

Another domain of application is the cooperation in order to take a local decision about the data to be sent. Unlike a centralized architecture where all data are loaded in a server leading to a significant transmission consumption, a local cooperation will take the advantage of sensor diversity and will send only the pertinent data in order to save energy with the best radio-computation trade-off, and eventually harvesting. It is also a solution to respect the privacy.

In spite of this ability of cooperative schemes to increase the energy efficiency of WSN, there is still very few practical experiments since they need both hardware and software improvements. The existing MAC layer protocols are not well suited to cooperative schemes and cooperative MAC protocols have to be designed. Cross-layer optimizations will then be investigated in our team to reach the maximum energy efficiency.

**Cooperative MIMO and relay techniques** The transmission mode classically used in wireless sensor networks to transmit a message from a source to a destination separated by a fairly large distance is multi-hops or multi-stages. However, some cooperative techniques allow an increase in the radio range of devices or a reduction in energy spent to reach the same distance.

- Relay techniques: Amplify-and-Forward (AF) and Decode-and-Forward (DF)
- Cooperative MIMO strategies (Fig 5)
- Opportunistic routing

The GRANIT team addresses these different possibilities taking especially into account the energy criterion, the most important constraint in wireless sensor networks. Besides performance evaluation through analytical derivations, the cooperative strategies are also simulated through network simulators. This implies the design of dedicated MAC protocols, but makes us able to estimate with accuracy the real gain of cooperation. Among the metrics we use, the energy-delay trade-off is very interesting for wireless sensor networks.

**Cooperative and opportunistic protocols** Although there is obviously an enormous interest in cooperative techniques in the research community, most of the performance analysis for cooperative communication is widely studied at physical layer. In order to make cooperative techniques be able to be utilized in the next generation of wireless networks, the higher layer protocols such as medium access control (MAC) layer or routing layer, must be thoroughly considered. Among the higher layers, MAC layer is responsible for regulating the shared wireless

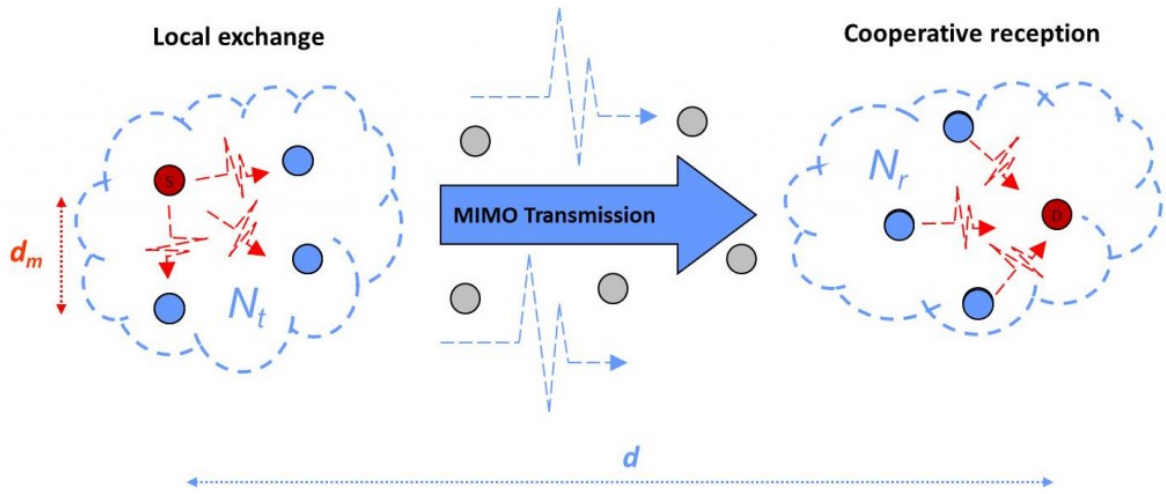

Figure 5: Cooperative MIMO transmission. Phase 1: the source exchanges information with its neighbors. Phase 2: synchronous MIMO transmission towards the destination group. Phase 3: the receiver sends the received signals towards the destination which combines the signals received.

medium access of the networks, therefore, it has great influences on the network performance. In addition, MAC layer is also expected to improve throughput or energy efficiency, reduce delay while keeping the collisions to a minimum.

On the other hand, opportunistic routing aims at exploiting sporadic radio links to improve the connectivity of multi-hop networks and to foster data transmissions. However, the benefit of opportunistic relaying may be counteracted due to energy increase resulted from multiple active receivers. Therefore, we are conducting thorough analysis of opportunistic relaying efficiency under the different realistic radio channel conditions, to find the optimal tradeoff between two objectives: energy and latency minimizations, with a hard reliability constraint.

**MIMO precoding** In the last decades, MIMO systems were exploited to offer spatial diversity and precoders were designed for a closed-loop solution with the channel state information at the transmitter through a feedback link. Some well-known solutions optimize the capacity, the mean square error, the signal to noise ratio or the minimum distance. Nowadays, it exists a lot of different precoders with pros and cons and, according to the environment and quality of service, the challenge is to choose the most energy-efficient solution. The main concerns of our research are the performance evaluation and the decrease of the complexity thanks to approaches based on the minimum distance ( $d_{min}$ ) and its probability density function (pdf).

Hereafter are some of the research paths we are following :

- Obtain the pdf of  $d_{min}$  for any precoder : modulation size, number of substreams, even a cooperative scheme with synchronization error
- Consider several channel statistics (Rayleigh, Rice, correlation), ie BAN, indoor, or outdoor context

- Propose new quantization methods of the feedback link in order to adapt the method from the open-loop to the full CSI and associated architecture solutions for precoders
- Propose new estimates of the bit error rate and extend it to channel coding with soft or iterative decision

Precoding techniques can also be used in a cooperative manner for wireless sensor networks. As stated here above, when propagation channels are varying slowly enough, it makes it even possible to distribute the precoding among cooperative nodes to dynamically adapt the signal transmission to the propagation channels and avoid deep fading.

## 4 Application Domains

### 4.1 Next generation of mobile communications

The next generation of wireless communications, namely 5G, will address a new kind of user: in addition to connect people, the next breakthrough is the connectivity of machines with other machines, referred to as 'M2M', which is the basis of the IoT paradigm<sup>6</sup>. Thus, in addition to a massive increase in the number of accesses (i.e. throughput increase) and current spectrum crisis issues, new requirements must be taken into account. A claimed advantage of M2M is remote steering and control of real and virtual objects. Hence, the required latency of such communications must be low enough to enable a round-trip delay from devices through the network back to devices of approximately 1ms. Another requirement we want to highlight is the flexibility the connected objects must have to respond to the number of standard modes. Indeed, in order to meet the time and space fluctuations of a service (i.e. throughput), in order to make several classes of objects connect together and in order to answer the spectrum scarcity issue, it is claimed that the new generation of wireless communications must be able to change their features in real time. Finally, reducing energy consumption is an on-going major challenge for two reasons: the first is the total energy consumption of ICT (Information and Communications Technologies) infrastructure that must be reduced; the second is the life cycle of new types of devices (e.g. Wireless Sensor Network node, IoT device) that must significantly increase to be massively deployed and used.

### 4.2 Wireless Sensor Networks

Wireless Sensor Network (WSN) technologies are also fast becoming a major part of our life with applications ranging from mobile health, smart homes, energy efficient buildings, environmental/context monitoring, assisted living, etc. The progress in this area is fast paced with power consumption reduction being one of the main challenges. One of the major promising advances is in the area of smart sensors where the computation is close to the sensor and only information or a command is being transmitted. This concept promises drastic savings of power, improvements in security, but also brings new challenges in areas such as ultra low

---

<sup>6</sup>G. Fettweis, The Tactile Internet - Applications & Challenges, *IEEE Vehicular Technology Magazine*, March 2014

power acquisition platforms, novel signal processing, and ultra low power reliable communications. Wireless Body Area Networks (WBAN) are a subclass of WSN, where the sensors are close to the body. This characteristic brings some of the biggest constraints in designing these networks in terms of power, size, security, reliability, etc. Despite these constraints, WBAN are listed as one of the most promising applications of WSN with many potential applications in health, rehabilitation, sports, and entertainment.

## 5 Hardware and Software

### 5.1 PowWow platform for WSNs

We have proposed and developed PowWow (Power Optimized Hardware and Software Framework for Wireless Motes), a hardware and software platform designed to handle sensor networks and related applications. The main innovating features of the platform are: an energy-efficient MAC protocol (15x less power than the ZigBee standard was reported for equivalent applications), a much more light memory usage, a low-power FPGA for acceleration of part of the software stack (energy reduction of two orders of magnitude was reported for error control and correction) and, more recently, a board including small-scale energy harvesting features, as illustrated on Fig. 6. Our work takes benefit from PowWow to perform power measurements that can be directly introduced in energy consumption models, leading to very precise predictions for the class of preamble sampling MAC protocols. We strongly rely on this platform for the prototyping of future research in this domain.



Figure 6: PowWow WSN Platform with Energy Harvesting

### 5.2 Energy autonomous LPWAN nodes (AMALO)

The board AMALO (AutonoMous energy hArvesting LONG range) has been made as part of the collaborative project ALAMO with local companies (Europrocess and CG Wireless). The main aim of this system is to have a platform interfaced with several sensors that can

harvest energy and transmit information with a long range radio module. We choose to use the LPWAN LoRa technology mainly because of its flexibility. It can be used in standalone (LoRa) or as part of a standardized protocol (LoRaWAN) with private or public network.

On the block diagram on the left of the Fig. 7, two features can be identified: Energy Harvesting and Processing. Firstly, the Energy Harvesting block is made up of the energy manager chip (SPV1050), the energy source (solar panel, Peltier module, etc.), an energy storage (a super-capacitor and/or a battery) and a chip able to measure the battery current and voltage. Secondly, the Processing block consists of the Murata CMWX1ZZABZ-078 chip and the sensors (with the click-board header and/or the buses header). Click-board header allows us to easily update sensors like temperature, humidity, motion, etc. or add new radio modules and controller. We can see the different elements of the AMALO board on the described board picture (on the right of the Fig. 7).

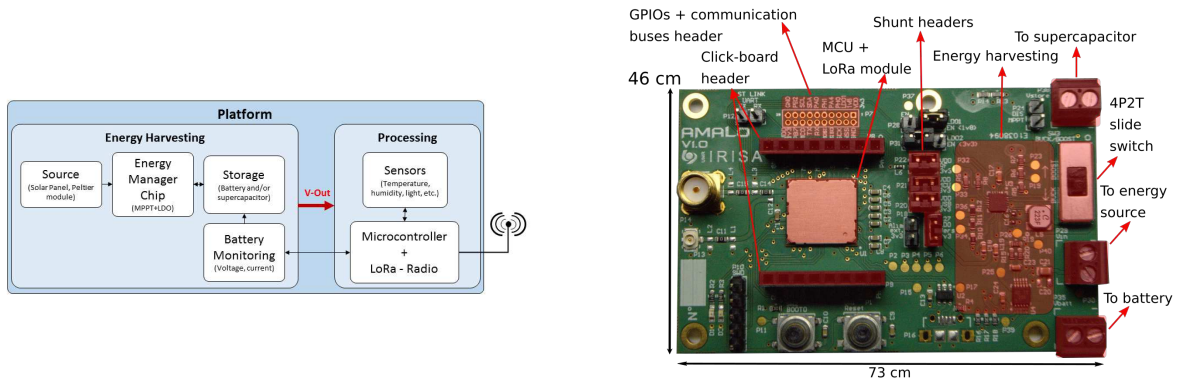

Figure 7: AMALO Block diagram (left) and described board picture (right)

One of the objective of this project was also to define a methodology for sizing energy harvesting components. The proposed methodology must define both energy storage devices (i.e. sizes of battery and capacitor) and harvesting components (i.e. solar panel area) of the AMALO platform. These elements depend on QoS parameters, hardware characteristics and environmental harvesting conditions.

### 5.3 Wireless Body Area Networks (Zyggie)

Zyggie is a motion capture platform design within the labex Cominlabs BoWI project. It consists of a set of electronic components (nodes) arranged on a part or the whole body of a person. The Inertial Measurement Unit (IMU) embedded in these nodes can duplicate the movement on an avatar moving on an Android tablet, as shown by Fig. 8. Communication between nodes is performed by radio and extensive energy optimization allows them an operating autonomy of 20 hours. As recharging nodes batteries also occurs wirelessly, it is therefore possible (even if this is not the case for current prototypes) to embed them in a waterproof box.

This state-of-the-art platform has enabled to thoroughly analyze BAN sensor network related challenges dedicated to motion capture. Our work focused primarily on opportunities to dispense with the energy intensive gyroscope, using radio power information received by

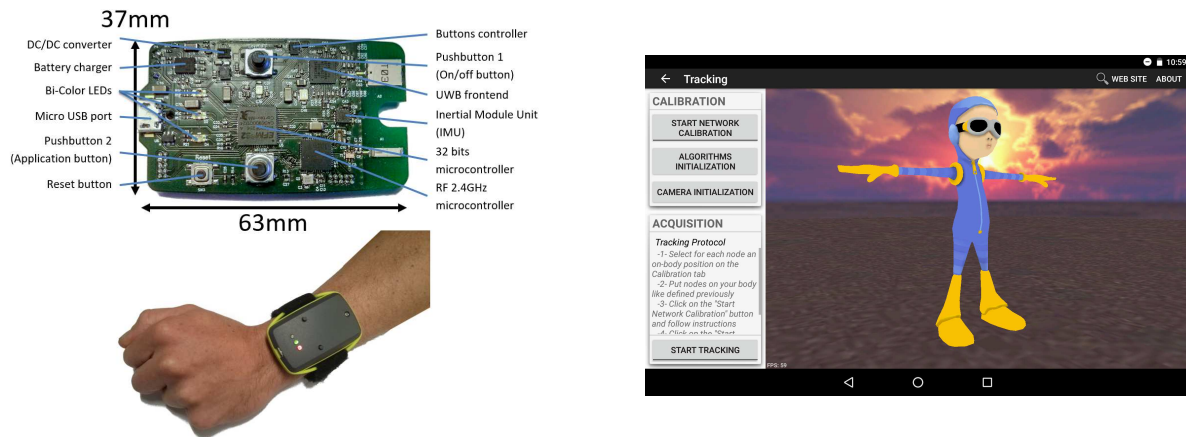

Figure 8: Zyggye motherboard and avatar application

the sensor network. The applications are animation, functional rehabilitation, optimization of sports movements, robotics, non-verbal communication in fighting situations. A new version of this platform was recently designed [9], that incorporates an Ultra Wide Band (UWB) radio for more precise positioning of the sensors.

#### 5.4 SDR platforms

In the context of SDR paradigm, GRANIT team studies the rapid prototyping of flexible radio waveforms leveraging High Level Synthesis. Both algorithms and architectures are taken into account to target heterogenous (software and hardware) SDR platforms. During the Equipex FIT, GRANIT members have experienced the Nutaq Perseus platform to validate our research by targeting two standards (IEEE 802.15.4 and IEEE 802.11a). We currently use Zynq-based platform from Xilinx to achieve the above mentioned heterogeneity.

The ROSE platform (Software Defined **R**adio Platform for **IoT** heterogeneous embedded systems) has been deployed in 2017. The platform is composed of several USRP-310 devices from Ettus. These SDR belong to the new generation where the architecture is based on both a PS (processing system, here a dual core CPU) and a PL (programmable logic, e.g an FPGA); based on Zynq platform. The SDR platform has been partially funded by the Brittany region (CD22) and by the University of Rennes.

#### 5.5 Real-time FPGA processing for optical access networks

Designed during the ANR FAON project, this platform is a prototype for 1Gbit/s QAM receiver for the optical access networks with Frequency Division Multiplexing (FDM). This prototype is based on a Virtex 7 FPGA and four analog to digital convertors sampling at 1 Gsps. This real-time prototype validates our algorithms for equalization and synchronization, but also a new FPGA design flow based on HLS (High Level Synthesis) and finally, the feasibility of frequency multiplexing for access networks. The prototype has been realized in collaboration with UMR CNRS FOTON for the RF front-end and Orange Labs for the integration in the

system and the tests. The GRANIT team has designed the algorithms for demodulation as well as the FPGA implementation.

## 5.6 FICOP: Foton Irisa Common Optical Platform

To achieve the vision of a distributed, programmable and flexible infrastructure facing the ever growing data volume and the cloudification of services, there is a necessity to investigate, design and experiment transport networks with high bandwidth capacity and agility for smart adaptation to application needs, based on reconfigurable optical systems controlled by software-defined networking (SDN) approaches.

To explore those issues a new optical platform was created between IRISA and Foton laboratories to merge skills of both teams, respectively on digital signal processing and optical communications. This platform was founded with CPER project and allows off-line 30GHz communication link. With 100Gsps Oscilloscope and 88GHz arbitrary waveform generator this equipment is use to design and test new algorithms to enhance next generation optical links.

# 6 New Results

## 6.1 Software Defined Radio

**Participants:** Robin Gerzaguet, Matthieu Gautier, Mai Thanh Tran.

Software Defined Radio (SDR) aims to revisit the paradigm of RF architectures. Classic RF architectures are massively integrated, hardware oriented, and can not cope with various bandwidths and carrier frequencies. SDR deports the processing in a software part through the use a general purpose processor (GPP) or digital signal processor (DSP). The processing can be done with the use of high level language such as C++ and Python. This paradigm change allows to use flexible devices that are able to address a wide frequency range (typically from 100MHz to 3-6 GHz) and different services and applications. As this flexibility is at the price of real time performance, new high performance SDR now embed hardware accelerator, mainly based on FPGA in a SoC architecture. However, how to use efficient design flow and take advantage of the hardware accelerator are still open questions. The PhD thesis defended by Tran in 2018 [1] is dedicated to this subject and proposes several methods in order to efficiently use high level synthesis techniques (HLS) in the SDR design flow and to efficiently reconfigure the FPGA part of the SDR during runtime.

Using SDR allows also to have real time demonstrators and to bridge the gap between upstream research and actual functional systems. In upcoming 5G, several parameters (also called numerologies) will coexist in order to address the large variety of services (broadband, low latency, low power ...). However, the orthogonality of these different signals cannot be maintained. In [10] we have conducted a mathematical analysis of the residual inter-numerology interference, and we show that the signal integrity cannot be maintained without additional filtering and/or processing. In [5], we have proposed a complete general framework on precoded filterbank which allows to have OFDM compatible waveform with additional filtering at the transmitter side. The waveform can still rely on an OFDM decoder but exhibits better performance in



coexistence scenario thanks to the additional filter stage. We have derived the mathematical formulae to allow a near perfect reconstruction, optimize different pulse shape filters and proposed several parameters that allow a perfect compatibility with an 5G NR receiver.

## 6.2 Energy Harvesting and Power Manager Design

**Participants:** Olivier Berder, Matthieu Gautier, Philip Dylan Gleonec.

Energy harvesting is a promising approach to enable autonomous long-life wireless sensor networks. As typical energy sources present time-varying behavior, each node embeds an energy manager, which dynamically adapts the power consumption of the node to maximize the quality of service, while preventing power failure.

In [2], RLMan, a novel energy management scheme based on reinforcement learning theory, is proposed. RLMan dynamically adapts its policy to time-varying environment by continuously exploring, while exploiting the current knowledge to improve the quality of service. The proposed energy management scheme has a very low memory footprint, and requires very few computational power, which makes it suitable for online execution on sensor nodes. Moreover, it only necessitates the state of charge of the energy storage device as an input, and therefore is practical to implement. RLMan was compared to three state-of-the-art energy management schemes, using simulations and energy traces from real measurements. Results show that using RLMan can enable almost 70% gains regarding the average throughput.

Most of energy manager algorithms have been implemented and evaluated in simulation frameworks. In [18], we evaluate the implementation of some algorithms to manage the energy of real-world LoRaWAN IoT nodes. We measure and compare the performance of the different energy budget estimation methods on a commercial LoRaWAN IoT platform. Results show that in this use-case, the choice of algorithm impacts the system Quality of Service by less than 15%. This enables much simpler energy budget estimation methods to be used. A demonstration of this real world LoRaWAN platform has been presented in [13], showing the implementation and the comparison of multiple energy manager algorithms.

Finally, the simultaneous use of multiple sources has been addressed to tackle the time-varying characteristics of certain sources. In this context, [14] presents a methodology aimed at classifying the energy sources to choose the most efficient energy manager. Feature extraction and selection phases can be processed and analyzed offline before deployment, and only a subset of features will be needed by the nodes to achieve efficient energy management. Simulations on real energy traces show that the proposed approach achieves classification accuracy higher than 95% through the computation of 4 features only.

## 6.3 Wake-up radio

**Participants:** Olivier Berder, Antoine Courtay, Matthieu Gautier.

In the recent years, ultra low power Wake-up Receivers (WuRx) have emerged as a possible solution to achieve both energy efficient communications and low latencies. Indeed, these devices allow continuous channel monitoring while consuming orders of magnitude less power than traditional transceivers, therefore enabling "pure-asynchronous" communications.

By using a generic framework based on absorbing Markov chains for modeling MAC protocols, which focuses on energy consumption, latency and reliability, it is possible to compare different schemes and evaluate new approaches, such as WuRx. In [8], experimental measurements on real hardware were performed to set framework parameters with accurate energy consumption and latency values, therefore proving the interest of WuRx based MAC protocols.

In [3], an energy manager combined with an asynchronous MAC protocol called SNW-MAC (Star NetworkWuRx - MAC) has been proposed for energy harvesting wireless sensor networks. The proposed solution leverages two complementary technologies, energy harvesting and ultra-low power wake-up receivers, to increase the energy efficiency of wireless sensor networks and to enable energy neutrality. This new scheme is designed to be implemented on real hardware, and therefore solely requires the measure of the residual energy achieving a negligible overhead. Experimental results showed that a 2.5 gain in term of throughput can be achieved by SNW-MAC. The energy efficiency was evaluated using a new metric introduced in this work, the energy utilization coefficient. Moreover, the better scalability of the proposed MAC protocol compared to traditional pseudo-asynchronous MAC has been analytically demonstrated.

When the addressee is far from the source node (eventually out of the radio range of the latter) multi-hop routing is commonly used, which consists in using one or several relays to help forwarding information. A novel MAC protocol that leverages the use of wake up receivers in multihop wireless sensor networks was presented in [11]. It uses energy based back-off mechanism to allow nodes to choose the best transmission schemes (relay or not). The proposed approach has been implemented on a real hardware platform. Performance evaluation combining analytical and microbenchmark demonstrates the benefits of the proposed approach in terms of energy efficiency.

## 6.4 Long range communications

**Participants:** Olivier Berder, Fayçal Ait Aoudia, Matthieu Gautier, Baptiste Vrigneau, Robin Gerzaguët, Malo Mabon, Mickaël Le Gentil, Xuan Chien Le.

LoRa is a technology for long range wireless communications that allows the development of new applications in domains such as smart agriculture, smart city or smart industry. Many in-field deployments and measurement campaigns have been performed in recent years, showing the sensibility of such communication to fading channels. In [15], the LoRa transmission reliability is evaluated in simulations for different fading channels. Moreover, as the energy consumption also depends on the configurations, a trade-off between energy consumption and reliability needs to be considered when selecting a LoRa configuration. To this aim, experimental energy measurements are performed on a Semtech device, showing that energy difference between various configurations can reach up to two orders of magnitude. Results highlight that LoRa configuration impacts the energy/reliability trade-off and the best one strongly depends of the type of channel.

To achieve both energy efficient and low latency communication in heterogeneous long-short range networks, a hardware architecture combining Wake-up radio and LoRa as well as a dedicated protocol was proposed [4]. Experimental measurements and analytical comparisons show that the proposed approach remove the need for a trade-off between power consumption

and latency.

## 6.5 Indoor Localization

**Participants:** Olivier Berder, Arnaud Carer, Antoine Courtay, Mickaël Le Gentil, Pascal Scalart.

Nowadays, there is a high demand for human and/or objects monitoring/localizing in the context of applications like Building Information Modeling (BIM), automated drone missions, contextual visits of museum or sports monitoring for instance. While for outdoor positioning accurate and robust solutions (i.e. GPS) exist for many years, indoor positioning is still very challenging. There is also a need of gesture/motion tracking systems that could replace video solutions. We proposed in [9] a hardware/software platform named *Zyggie* that combines both Ultra Wide Band (UWB) technology and Received Signal Strength Indicator (RSSI) for low power accurate indoor positioning and Inertial Measurement Unit (IMU) utilization for motion tracking. Very few industrial/academic existing solutions can simultaneously perform indoor positioning and motion tracking and none of them can do both under low power, low cost and compacity constraints addressed by our platform. As *Zyggie* has the capability to estimate distances w.r.t other platforms in the environment and quaternions (which represent the attitude/orientation) users can test/enhance state of the art algorithms for positioning and motion tracking applications.

A positioning algorithm named Best Anchor Selection for Trilateration (BAST) based on position prediction and noise estimation was proposed in [16]. An experimental testbed using real cases experiments on *Zyggie* shows that BAST can give from 1.26 up to 4.17 times better accuracy than low complexity state of the art algorithms when the mobile/person is in movement (e.g. tennis player).

## 6.6 Non Intrusive Load Monitoring

**Participants:** Nicolas Roux, Baptiste Vrigneau.

Knowing the plug-level power consumption of each appliance in a building can lead to drastic savings in energy consumption. Non-Intrusive Load Monitoring (NILM) is a method for desegregating power loads in a building to the single appliance level, without using direct sensors or electric meters. This paper addresses the issues of inaccuracy of NILM in commercial and industrial buildings, by deploying a low-cost, non-dedicated, smart sensors network in our lab: the SmartSense platform. The SmartSense platform gathers environmental data and allows us to make a rough guess on the states of the monitored appliance. The simplex algorithm is used to estimate the power load values of these steady states, and transmit it to the next sliding window of data [19].

## 6.7 MIMO Precoding and cooperative Communications

**Participants:** Olivier Berder, Baptiste Vrigneau.

In [6], we propose an imperfect quantized feedback-based diagonal precoding scheme for generalized orthogonal space-time block codes in an  $N \times 1$  multiple-input single-output (MISO) wireless communication system employing M-QAM constellation. It is well known that a feedback-based precoding scheme aids channel adaptive signaling in wireless communication system and capitulates large improvements in almost all performance metrics. However, a practical feedback link is susceptible to error due to wireless channel fading and leads to wrong precoder selection. Therefore, a signal-to-noise ratio (SNR) adaptive error-tolerant weighting scheme is introduced which provides significant gain in comparison with another proposed arbitrarily fixed SNR error-tolerant weighting scheme. At first, a tight approximate closed-form expression of average symbol-error-rate (SER) and an exact analytical expression of outage probability are derived under imperfect feedback information with the help of order statistics. By minimizing the derived average SER, optimized transmit weights for the diagonal precoding matrix (based on feedback bits) are obtained. Later, a closed-form expression of the ergodic capacity with erroneous feedback bits for arbitrary MISO system is also provided by using the moment generating function approach. Further, numerical results show that the considered error-tolerant schemes outperform the uniform power allocation scheme in term of all the investigated performance metrics.

Distributed MIMO precoding can also be considered for energy efficient wireless sensor networks since it benefits from the high spectral efficiency of a spatial multiplexing system. However the performance evaluation of such systems is rather complex due on one hand to the precoding process itself and on the other hand to the cooperative aspects. We described a distributed precoding amplify and forward scheme that considers the maximization of the minimum Euclidean distance as design criterion. This solution provides many advantages in terms of performance and spectral efficiency but a optimal power allocation is needed. Thus, the performance evaluation is rigorously achieved by, firstly, investigating the distribution function of Euclidean distance between two received points and, secondly, by deriving the channel capacity. The accuracy of our analytical solution is proven by Monte Carlo Simulations of a 2 x 2 distributed MIMO system, before power allocation optimization is carried out according to the capacity.

## 6.8 Optical Communications

**Participants:** Arnaud Carer, Robin Gerzaguet, Pascal Scalart.

M-ary quadrature amplitude modulation (M-QAM) in combination with coherent detection and digital signal processing (DSP) becomes now a promising candidate for next generation optical transmission systems. This is made possible notably thanks to technical progress in photonic integrated circuits (PICs) allowing the fabrication of monolithically integrated optical circuits for M-QAM optical signal generation. Despite the amazing performance of these circuits, there are still some issues, in particular concerning the nonlinear gain of electrical amplifiers, the control of phase shifts in optical waveguides and cable lengths or circuit paths on printed boards. For all these reasons the resulting signal may present gain and/or phase imbalance (globally referred to as IQ imbalance) and suffer from channel effects, polarization dispersion and phase errors. All these impairments affect the signal integrity and lower the

received signal to noise ratio (SNR). Hence, digital compensation methods have to be developed in order to decode the received data.

Besides that, modern network architectures are based on flexible and adaptive (re)-transmissions. Hence, some modulation parameters, such as pulse shape filter and modulation order, can change over time in order to adapt to the link quality. Besides that, optical parameters (such as impairments level) can change over time due to network reconfiguration. As a consequence, the proposed algorithms should be adaptive and able to track time varying parameters in a short horizon. In [12], a new adaptive step-size overlay has been proposed (in the scope of Least Mean Square Algorithm). Mathematical properties of this method have been studied and a comparison with several well-known state of the art methods have been conducted. It shows promising result when reconfigurations (sudden changes in the parameters to track) occur.

In [7], we comprehensively investigate an alternative method for IQ imbalance compensation based on the definition and computation of a suitable novel metric for the detected signal, in order to estimate and compensate for the phase imbalance. The approach using this new metric, called best-matched signal estimation method (MSEM), provides an interesting alternative to existing algorithms thanks to its reduced complexity and a comparable performance. More particularly, main contributions are: (i) a comprehensive analytical analysis of the proposed IQ imbalance compensation method; (ii) numerical validation of the derived analytical expression in the presence of additive noise; (iii) finding and numerically proving the existence of a small deterministic bias of the estimated phase imbalance. These new contributions strongly confirm our experimental results of the proposed IQ imbalance compensation method. Moreover, the proposed method requires no square-root operators, which can make its implementation in hardware platforms simpler. Furthermore, this method provides information on the phase imbalance value between I and Q components, which can be helpful for the characterization and calibration of the IQ modulator or the coherent receiver. Regarding the bit-error-rate (BER) and the error vector magnitude (EVM) of compensated constellations, the proposed MSEM algorithm matches that of the Gram-Schmidt orthogonalization procedure (GSOP) approach, while its implementation complexity is reduced.

## 7 Contracts and Grants with Industry

### 7.1 CIFRE PhD Grant Wi6Labs

**Participants:** Olivier Berder, Matthieu Gautier, Philip Dylan Gleonec.

This is a Cifre contract with Wi6labs compagny that includes the supervision of Philip Dylan Gleonec. The goal of this thesis is the design and the implementation of power management strategies for long range radio modules equipped energy harvesting.

### 7.2 Eco-counter

**Participants:** Arnaud Carer, Mickaël Le Gentil, Pascal Scalart.

The company Eco-counter needed to update its bike counting system to maintain the

competitiveness of its product with increased competition. Granit team suggested the use of a component initially designed to produce contactless buttons. A service is on-going with the company to validate this new technological solution and to propose algorithmic improvements.

### 7.3 Feichter electronic

**Participants:** Arnaud Carer, Pascal Scalart.

This work aimed at designing a radio system for high-quality audio streams, since none of the existing systems on the market was meeting the requirements of the society. This collaboration resulted in a co-supervised internship to evaluate the possible technologies. Because of the satisfactory results of the internship, the collaboration is still on-going.

### 7.4 Orange

**Participants:** Arnaud Carer, Antoine Courtay, Mickaël Le Gentil.

This work was done with Orange in order to design an autonomous robot for Wifi network supervision. The designed robot can autonomously move in a building environment following some predefined paths, and hold some Wifi connected devices such as smartphones, tablets and/or computers. These devices can connect/disconnect to several Wifi access points in the environment. Tests were done by humans following these trajectories.

## 8 Other Grants and Activities

### 8.1 International Collaborations

- **EU CELTIC+ SENDATE TANDEM (2016-2019)**

**Participants:** Olivier Berder, Arnaud Carer, Pascal Scalart

TANDEM is sub-project from the CELTIC+ SENDATE project. TANDEM addresses the challenge for a new network infrastructure with reference to high volatile data traffic of mobile linked up objects. A dynamic switching and a reliable transport of huge amounts of data as well as a handover of sensible, time critical application data without any interruptions must be provided between data centers.

Within the metro area, essential elements are virtualized: integrated nodes consisting of traditional DCs (RAM, processor) but also e.g. virtualized DSL- and radio access (vRAN) network elements or IP-router and optical network elements like cross-connects. Virtualization shall lead to a flexible arrangement of single modules and to a dynamic provision of resources according to application demands. Here latency and bandwidth but also QoS classes and findings from simulative traffic investigations will be considered.

Furthermore a common SDN-based control-plane will be developed for an optimized control of network elements across levels. The first underlying assumption is based upon a flexible control plane and develops an application, which is able to migrate the network

from one load status to another. The second assumption goes for full flexibility from scratch within definition of control plane architecture, intending to turn today's metro networks into a flexible platform for future services and applications.

Elastic Optical Networks (EON) are now widely deployed because they can reduce the number of opto-electronic regenerators, take advantage of new flexi-grid ROADMs and provide improvements in tunable laser or DSP technologies. To efficiently benefit from multiple rates in EON and to optimize the limited spectral resources over time, optical spectrum defragmentation is required. Today, we use defragmentation during maintenance windows because lightpaths must be often switched off to be able to move the wavelength over the C band. In EON, defragmentation may become challenging when using different spectrum grids. To overcome this, automation is needed. Experiments were conducted with an SDN control without studying optical hardware network elements. In [17], we propose a solution to deploy optical spectrum defragmentation automatically, with fast hardware elements and SDN control. The process may also include lightpaths rerouting without traffic interruption. We first present the architecture and depict how to allow a fast SDN-based defragmentation. We then set up an experiment and perform hardware characterizations.

The findings will be applied to a virtual communication-based Internet of Things network.

The TANDEM project involves some academics (UR1, IMT, Stuttgart, Fraunhofer) and many industrials, among which we can cite Nokia, Orange, Thales, Vectrawave, Telenor... For more details see <https://www.celticplus.eu/project-sendate-tandem/>.

## 8.2 National Collaborations

- **Images & Réseaux Competitivity Cluster - ALAMO (2016-2018)**

**Participants:** Olivier Berder, Matthieu Gautier, Baptiste Vrigneau, Mickaël Le Gentil  
ALAMO (Autonomous Long rAnge radio Modules for cOnnected farms) is a project that will allow farms to have a dedicated box to connect sensors with heterogeneous radio communications. The project involves Granit teams and two Small Medium Enterprises (SMEs): Euro-Process and CG-Wireless. The key features of the proposed system are optimized radio protocol, long range, low power consumption, providing a ready-to-use brick for integrator of digital solutions. Granit goal is to provide our skills on the energy management in sensor node and to address fundamental limits of long range communications. This project received **Innov'Space award** at SPACE 2018, the main event for agriculture professionals in Europe.

- **Images & Réseaux Competitivity Cluster - Plug&Pos (2017-2019)**

**Participants:** Olivier Berder, Antoine Courtay, Mickaël Le Gentil

Plug&Pos is a project focused on indoor geolocation applied to museum applications. Challenges are to create an accurate indoor geolocation system and to propose interactive information on tablets to visitors. To achieve this aim, Granit team works on geolocation algorithms for facing to environment perturbations due to distance measuring with UWB radio. The first industrial partner is Ticatag for the prototyping phase and the second partner is Regard Services to propose contextual information with video, audio and

augmented reality contents. The complete system must be installed quickly, support multi-users and be accurate with  $\pm 20$ cm to differentiate nearby points of interest.

- **Images & Réseaux Competitivity Cluster - HAD-OC (2018-2020)**

**Participants:** Antoine Courtay, Arnaud Carer, Olivier Berder, Mickaël Le Gentil

The development of immersive technologies (augmented reality, virtual reality) offers an important opportunity in the audio field. Sound represents 50% of the immersion quality and is therefore a key factor in the user experience. However, technologies for the transmission and the processing of audio data have not evolved as fast as the virtual reality ones did. The HAD-OC project aims at developing a wireless audio transmission solution compatible with 3D professional sound requirements. The bit rate will be at least 4.6 Mbps and the latency less than one millisecond. To meet the needs of 3D sound and virtual reality, the system will allow 3D geolocation of transmitters / receivers. We will demonstrate in the project point-to-point transmission and broadcast transmission. To do so, Feichter Electronics, 3D Ouest and the Granit team will join forces to develop a method for wireless transmission of a high quality digital audio signal without latency.

- **ANR PRCE - Wake-Up (2017-2020)**

**Participants:** Olivier Berder, Antoine Courtay, Matthieu Gautier

Using pure-asynchronous communication allowed by emerging Ultra-Low-Power (ULP) wake-up receivers (WUR), Wake-Up aims at proposing a low latency and energy efficient network architecture composed of heterogeneous radio nodes (long-range communication and ULP short-range WUR) with dedicated access and network protocols. A two-way cross layer optimization is envisaged in Wake-Up, since on one hand these heterogeneous network higher layers will take into account the specificities of the wake-up radio to optimize energy and latency, and on the other hand some recurrent application constraints will lead to specific wake-up radio designs. The consortium is composed of two academic partners (University of Rennes 1 and University of Strasbourg), one state-owned industrial and commercial establishment (CEA LETI) and one SME (Wi6Labs). The consortium will address these scientific challenges at both the node and the network levels, with controlled (FIT IoT Lab) and real-field experimental validations.

- **Labex Cominlabs Moonlight (2018-2019)**

**Participants:** Olivier Berder, Mickaël Le Gentil, Antoine Courtay

In order to enhance sportsmen performance, various sensors are employed in controlled environment to monitor both physiological values and gesture accuracy. However, most of these monitoring platforms are either bulky, heavy or very expensive, which makes them not suitable for everyday monitoring in training conditions. The goal of Moonlight is to design a light wireless sensor platform for accurate sport monitoring, even in outdoor training conditions. The first intended use case is cycling, since the platform will feed biomechanics algorithms, jointly designed with M2S laboratory to quantify power transfer from the cyclist to cycle and help avoiding injuries.



## 9 Dissemination

### 9.1 Scientific Responsibilities

- O. Berder is a member of the Editorial Board of *International Journal of Distributed Sensor Networks*
- O. Berder is a member of the Editorial Board of *Wireless Communications and Mobile Computing*
- O. Berder is in charge of Embedded Systems theme of the GIS ITS (Scientific Interest Group on Intelligent Transportation Systems)
- O. Berder is a member of the Organization Committee of the annual colloquium Energ&TIC, Pleumeur-Bodou
- O. Berder was a member of Technical Program Committee of IEEE PIMRC and is a reviewer for IEEE TSP, TWC, ToN, JSAC, ICC, GLOBECOM
- O. Berder served as the president of the committee for the PhD defense of Hassan Harb, *Design Of Ultra-High Throughput Rate NB-LDPC Decoder*, defended at University of Bretagne Sud, November 8<sup>th</sup> 2018
- O. Berder served as a member of the committee for the PhD defense of Romain Chevillon, *Efficacité énergétique des communications Device-to-Device dans les réseaux hétérogènes*, defended at Université de Nantes, November 9<sup>th</sup> 2018
- O. Berder served as a reviewer for the PhD of Daniel Alshamaa, *Indoor Localization of Sensors : Application to Dependent Elderly People*, defended at Université Technologique de Troyes, November 13<sup>th</sup> 2018
- O. Berder served as the president of the committee for the PhD of Umber Noreen, *Modélisation d'Interférence pour Simulateur 3D de Réseaux de Capteurs Dédiés aux Villes Intelligentes*, defended at Université de Bretagne Occidentale, December 20<sup>th</sup> 2018
- O. Berder and M. Gautier are elected members of Research Commission of IUT Lannion
- A. Courtay served as a reviewer for IJDSN, PIMRC, ISCAS, ICT, ICECS.
- M. Gautier was a member of technical program committee of ICT, IEEE ISWCS, IEEE PIMRC, IARIA SENSORCOM, IARIA AICT and EAI CROWNCOM.
- M. Gautier served as a reviewer for MDPI Sensors and IEEE TSIPN.
- B. Vrigneau served as a reviewer for IEEE Communications Letters, PIMRC, ISTC, WCMC, MDPI Sensors, IEEE Trans. on Vehicular Technology.
- B. Vrigneau was a member of technical program committee of IEEE PIMRC and 4th International Workshop on Non-Intrusive Load Monitoring.

## 9.2 Involvement in the Scientific Community

- O. Berder gave a lecture entitled "Towards energy autonomous wireless sensor networks" at E3RSD (Research school for early stage researchers on Energy Efficiency of Networks and Distributed Systems), Dinard, 1st October 2018.
- O. Berder gave a invited talk entitled "Energy Harvesting and Management for IoT Sensors" at France Stratégie, Paris, 4th June 2018
- O. Berder gave a invited talk entitled "Energy Management for autonomous sensors" at common workshop between RSD and SoC2 GDRs "IoT, IA and Big Data for Distributed Sensors : Applications to Health and Environment", Toulon, 11th April 2018
- O. Berder gave a invited talk entitled "Near sensor computing : on the trade-off between local processing and data transmission" at GDR SoC2 annual meeting, Paris, 14th June 2018
- M. Gautier and R. Gerzaguet did a presentation entitled "High performance software radios : concepts, tools and applications" during the "Plateformes d'évaluations radio" day, GDR ISIS and RSD, March 2018
- M. Le Gentil, M. Gautier, B. Vrigneau and O. Berder presented AMALO platform at SPACE, main event for agriculture professionals in Europe, in Rennes, France, September 2018
- O. Berder, M. Gautier and A. Courtay organized a special session "Wake-up Radios: Circuits, Systems, and Applications" at IEEE ICECS, Bordeaux, December 2018.
- O. Berder and B. Vrigneau are members of scientific committee of IUT Lannion.

## 9.3 Teaching Responsibilities

IUT stands for *Institut Universitaire de Technologie* and ENSSAT stands for *École Nationale Supérieure des Sciences Appliquées et de Technologie* and is an *école d'Ingénieurs*. Both are located in Lannion and part of the University of Rennes 1.

- D. Demigny is a Vice-President of the University of Rennes 1, in charge of Digital Activities.
- D. Demigny is the Head of the Physical Measurements Department at IUT Lannion.
- P. Scalart is the Head of the Electronics Engineering department of ENSSAT.
- A. Courtay is supervising the first year students of the Electronics Engineering department of ENSSAT.
- M. Gautier is the Head of the Network and Telecommunications Department at IUT Lannion (since September).

- M. Gautier is member of the French National University Council since 2015 in signal processing and electronics (Conseil National des Universités en 61e section).
- O. Berder is in charge of Studies Pursuit of Physical Measurements Department at IUT Lannion.
- O. Berder and B. Vrigneau are elected members of IUT Institute Council and Direction Committee.
- B. Vrigneau is in charge of the project of new department Multimedia and Internet at IUT Lannion (scheduled on September 2020).

#### 9.4 Teaching

- O. Berder: signal processing, 70h, IUT Lannion (L2)
- O. Berder: sensors and control, 90h, IUT Lannion (L2)
- O. Berder: digital systems, 80h, IUT Lannion (L1)
- O. Berder: IoT and connected objects, 10h, ENSSAT (L3)
- A. Courtay: digital electronics, 122h, ENSSAT (L3)
- A. Courtay: digital system design, 12h, ENSSAT (L3)
- A. Courtay: PCB conception, 14h, ENSSAT (L3)
- A. Courtay: digital electronics communication interfaces, 68h, ENSSAT (M1)
- A. Courtay: digital electronics: Laser diode driver, 16h, ENSSAT (M1)
- M. Gautier: computer architecture, 36h, IUT Lannion (L1)
- M. Gautier: telecommunications, 138h, IUT Lannion (L1)
- M. Gautier: digital communications, 30h, IUT Lannion (L2)
- M. Gautier: IoT and connected objects, 10h, ENSSAT (L3)
- R. Rocher: electronics, 44h, IUT Lannion (L1)
- R. Rocher: telecommunications, 82h, IUT Lannion (L1)
- R. Rocher: signal processing, 12h, IUT Lannion (L2)
- R. Rocher: digital communications, 48h, IUT Lannion (L2)
- P. Scalart: non-linear optimisation, 18h, Master by Research (SISEA) and ENSSAT (M2)

- P. Scalart: parametric modelization, optimal and adaptive filters, 24h, Master by Research (SISEA) and ENSSAT (M2)
- P. Scalart: source coding, 14h, Master by Research (SISEA) and ENSSAT (M2)
- P. Scalart: cellular networks, 24h, ENSSAT (M2)
- P. Scalart: digital communication systems, 32h, ENSSAT (M1)
- P. Scalart: random signals and systems, 12h, ENSSAT (M1)
- R. Gerzaguet: Micro-electronics, 46h, ENSSAT (L3)
- R. Gerzaguet: Digital Signal processing, 60h, ENSSAT (M1)
- R. Gerzaguet: Wireless network, 9h, ENSSAT (M1)
- R. Gerzaguet: Wireless communication, 20h, ENSSAT (M2)
- R. Gerzaguet: System On Chips, 22h, ENSSAT (M2)
- B. Vigneau: computer architecture, 14h, IUT Lannion (L1)
- B. Vigneau: enterprise telephony, 20h, IUT Lannion (L1)
- B. Vigneau: maths, 24h, IUT Lannion (L2)
- B. Vigneau: telecommunications, 190h, IUT Lannion (L1, L2, L3)
- B. Vigneau: data acquisition, 25h, University of Science and Technology of Hanoi (M1)

## 10 Bibliography

### Doctoral dissertations and “Habilitation” theses

- [1] M.-T. TRAN, *Towards Hardware Synthesis of a Flexible Radio from a High-Level Language*, Theses, Université de Rennes 1, December 2018, <https://hal.inria.fr/tel-01942187>.

### Articles in referred journals and book chapters

- [2] F. AIT AODIA, M. GAUTIER, O. BERDER, “RLMan: an Energy Manager Based on Reinforcement Learning for Energy Harvesting Wireless Sensor Networks”, *IEEE Transactions on Green Communications and Networking*, February 2018, p. 1 – 11, <https://hal.archives-ouvertes.fr/hal-01701688>.
- [3] F. AIT AODIA, M. GAUTIER, M. MAGNO, O. BERDER, L. BENINI, “Leveraging Energy Harvesting and Wake-Up Receivers for Long-Term Wireless Sensor Networks”, *Sensors* 18, 5, May 2018, <https://hal.archives-ouvertes.fr/hal-01794082>.

- [4] F. AIT AOUDIA, M. GAUTIER, M. MAGNO, M. LE GENTIL, O. BERDER, L. BENINI, “Long-Short Range Communication Network Leveraging LoRa and Wake-up Receiver”, *Microprocessors and Microsystems: Embedded Hardware Design (MICPRO) 56*, February 2018, p. 184–192, <https://hal.inria.fr/hal-01666858>.
- [5] D. DEMMER, R. ZAKARIA, R. GERZAGUET, J. DORÉ, D. L. RUYET, “Study of OFDM Precoded Filter-Bank Waveforms”, *IEEE Transactions on Wireless Communications*, 2018, p. 1–1.
- [6] A. GARG, M. R. BHATNAGAR, O. BERDER, B. VRIGNEAU, “Quantized Feedback Based Diagonal Precoding for Nx1 MISO System with Generalized Orthogonal Space-Time Block Codes”, *IEEE Transactions on Communications 66*, January 2018, p. 91–104, <https://hal.inria.fr/hal-01635782>.
- [7] T. H. NGUYEN, P. SCALART, M. GAY, L. BRAMERIE, C. PEUCHERET, F. GOMEZ AGIS, O. SENTIEYS, J.-C. SIMON, M. JOINDOT, “New metric for IQ imbalance compensation in optical QPSK coherent systems”, *Photonic Network Communications 36*, 3, December 2018, p. 326–337, <https://hal.inria.fr/hal-01941892>.

## Publications in Conferences and Workshops

- [8] F. AIT AOUDIA, M. GAUTIER, O. BERDER, “Evaluation analytique des wake-up radios pour les réseaux de capteurs sans fil”, *in: Rencontres Francophones sur la Conception de Protocoles, l'Évaluation de Performance et l'Expérimentation des Réseaux de Communication*, Roscoff, France, May 2018, <https://hal.archives-ouvertes.fr/hal-01784560>.
- [9] A. COURTAY, M. LE GENTIL, O. BERDER, A. CARER, P. SCALART, O. SENTIEYS, “Zyggie: A Wireless Body Area Network platform for indoor positioning and motion tracking”, *in: ISCAS 2018 - IEEE International Symposium on Circuits and Systems*, IEEE, p. 1–5, Florence, Italy, May 2018, <https://hal.archives-ouvertes.fr/hal-01804927>.
- [10] D. DEMMER, R. GERZAGUET, J.-B. DORÉ, D. LE RUYET, “Analytical study of 5G NR eMBB co-existence”, *in: 2018 25th International Conference on Telecommunications (ICT), 2018 25th International Conference on Telecommunications (ICT)*, IEEE, St. Malo, France, June 2018, <https://hal.archives-ouvertes.fr/hal-01936001>.
- [11] N. E. H. DJIDI, A. COURTAY, M. GAUTIER, O. BERDER, “Adaptive relaying for wireless sensor networks leveraging wake-up receiver”, *in: IEEE International Conference on Electronics Circuits and Systems (ICECS)*, Bordeaux, France, December 2018, <https://hal.inria.fr/hal-01900670>.
- [12] R. GERZAGUET, L. ROS, F. BELVÈZE, J.-M. BROSSIER, “On multiplicative update with forgetting factor adaptive step size for least mean-square algorithms”, *in: International Conference on Telecommunication (ICT)*, Saint Malo, France, June 2018, <https://hal.archives-ouvertes.fr/hal-01820720>.
- [13] P.-D. GLEONEC, J. ARDOUIN, M. GAUTIER, O. BERDER, “A Real-World Evaluation of Energy Budget Estimation Algorithms for Autonomous Long Range IoT Nodes”, *in: International Conference on Telecommunication*, Saint-Malo, France, June 2018, <https://hal.archives-ouvertes.fr/hal-01816578>.

- [14] M. LAGHA KAZDOGHLI, F. AIT Aoudia, M. GAUTIER, O. BERDER, “Feature Selection Framework for Multi-source Energy Harvesting Wireless Sensor Networks”, *in: IEEE Vehicular Technology Conference (VTC-Spring)*, Porto, Portugal, June 2018, <https://hal.archives-ouvertes.fr/hal-01794094>.
- [15] X.-C. LE, B. VRIGNEAU, M. GAUTIER, M. MABON, O. BERDER, “Energy/Reliability Trade-off of LoRa Communications over Fading Channels”, *in: International Conference on Telecommunication*, Saint-Malo, France, June 2018, <https://hal.archives-ouvertes.fr/hal-01816574>.
- [16] M. LE GENTIL, A. COURTAY, O. BERDER, P. SCALART, S. FONTAINE, A. CARER, “Anchor Selection Algorithm for Mobile Indoor Positioning using WSN with UWB Radio”, *in: IEEE Sensors Applications Symposium (SAS)*, p. 1–5, Sophia Antipolis, France, March 2019.

### Miscellaneous

- [17] A. DUPAS, D. VERCHERE, Q. PHAM VAN, P. LAYEC, L. BRAMERIE, A. CARER, B. HAENTJENS, E. LE ROUZIC, “Easy Optical Defragmentation with SDN Controlled Tunable Transmitter”, 44th European Conference on Optical Communication (ECOC 2018), *2018 European Conference on Optical Communication (ECOC)*, September 2018, Poster, <https://hal.archives-ouvertes.fr/hal-01934746>.
- [18] P.-D. GLEONEC, J. ARDOUIN, M. GAUTIER, O. BERDER, “Demo Abstract: Multi-source energy management for Long Range IoT nodes”, International Conference on Telecommunication, June 2018, Poster, <https://hal.archives-ouvertes.fr/hal-01819048>.
- [19] N. ROUX, B. VRIGNEAU, O. SENTIEYS, “Estimating Power Loads from Partial Appliance States”, NILM 2018 - 4th International Workshop on Non-Intrusive Load Monitoring, March 2018, Poster, <https://hal.inria.fr/hal-01941877>.