

# On Decision Problems for Probabilistic Büchi Automata

Christel Baier<sup>1</sup>, Nathalie Bertrand<sup>2</sup>, Marcus Größer<sup>1</sup>

<sup>1</sup>TU Dresden, Germany

<sup>2</sup>IRISA, INRIA Rennes, France

Cachan – 05 février 2008

# Probabilistic Büchi Automata [Baier, Größer 05]

PBA = NBA with **probabilities** instead of non-determinism

# Probabilistic Büchi Automata [Baier, Größer 05]

PBA = NBA with **probabilities** instead of non-determinism

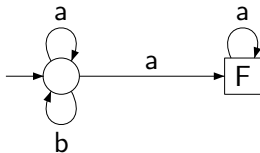

$$\mathcal{L}(\mathcal{A}) = \{w \in \Sigma^\omega \mid \exists \rho \in \text{Runs}(w) \text{ with } \rho \models \Box \Diamond F\}$$

# Probabilistic Büchi Automata [Baier, Größer 05]

PBA = NBA with **probabilities** instead of non-determinism

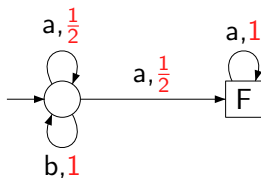

$$\mathcal{L}(\mathcal{A}) = \{w \in \Sigma^\omega \mid \mathbb{P}_{\mathcal{A}}(\{\rho \in \text{Runs}(w) \mid \rho \models \Box \Diamond F\}) > 0\}$$

$$\mathcal{L}_{\text{NBA}}(\mathcal{A}) = (a + b)^* a^\omega = \mathcal{L}_{\text{PBA}}(\mathcal{A})$$

# Probabilistic Büchi Automata [Baier, Größer 05]

PBA = NBA with **probabilities** instead of non-determinism

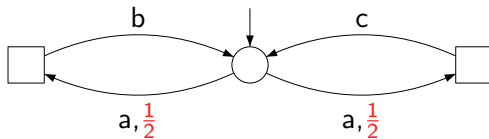

# Probabilistic Büchi Automata [Baier, Größer 05]

PBA = NBA with **probabilities** instead of non-determinism

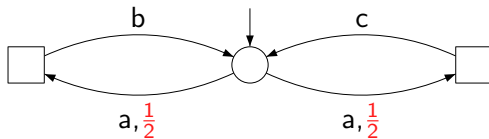

$$\mathcal{L}_{\text{NBA}}(\mathcal{A}) = (ab + ac)^\omega \text{ and } \mathcal{L}_{\text{PBA}}(\mathcal{A}) = \emptyset$$

# Expressiveness: PBA vs DBA

PBA are strictly more expressive than DBA

- ▶ any DBA  $\mathcal{A}$  can be turned into a PBA  $\mathcal{P}$

# Expressiveness: PBA vs DBA

PBA are strictly more expressive than DBA

- ▶ any DBA  $\mathcal{A}$  can be turned into a PBA  $\mathcal{P}$
- ▶ there is a PBA whose language can't be recognized by a DBA

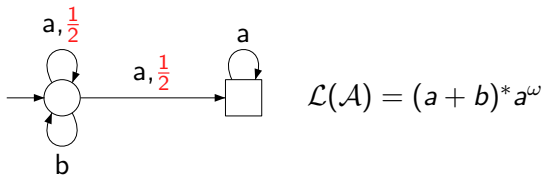

# Expressiveness: PBA vs NBA

PBA are strictly more expressive than NBA

- ▶ any NBA  $\mathcal{A}$  can be turned into a PBA  $\mathcal{P}$   
Trick: replace  $\mathcal{A}$  by an equivalent NBA **deterministic**  
**in the limit**

# Expressiveness: PBA vs NBA

PBA are strictly more expressive than NBA

- ▶ any NBA  $\mathcal{A}$  can be turned into a PBA  $\mathcal{P}$   
Trick: replace  $\mathcal{A}$  by an equivalent NBA **deterministic in the limit**
- ▶ there is a PBA whose language can't be recognized by an NBA

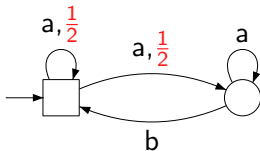

$$\mathcal{L}(\mathcal{A}) = \{a^{k_1} b a^{k_2} b \dots \mid \prod_i (1 - \frac{1}{2}^{k_i}) > 0\}$$

# Outline

- 1 Introduction
- 2 **Complementation**
- 3 Emptiness problem
  - Langage dependency on probabilities
  - Undecidability of emptiness
- 4 Alternative semantics
  - Expressivity
  - Emptiness problem
- 5 Conclusion

# Complementation

## Theorem

For each PBA  $\mathcal{P}$  there exists a PBA  $\mathcal{P}'$  with  $|\mathcal{P}'| = \mathcal{O}(\exp(|\mathcal{P}|))$  such that  $\mathcal{L}(\mathcal{P}') = \Sigma^\omega \setminus \mathcal{L}(\mathcal{P})$ .  
Moreover,  $\mathcal{P}'$  can be effectively constructed from  $\mathcal{P}$ .

# Complementation

## Theorem

For each PBA  $\mathcal{P}$  there exists a PBA  $\mathcal{P}'$  with  $|\mathcal{P}'| = \mathcal{O}(\exp(|\mathcal{P}|))$  such that  $\mathcal{L}(\mathcal{P}') = \Sigma^\omega \setminus \mathcal{L}(\mathcal{P})$ .  
 Moreover,  $\mathcal{P}'$  can be effectively constructed from  $\mathcal{P}$ .

## Proof Scheme

$$\mathcal{P} \text{ PBA} \longrightarrow \mathcal{P}_R \text{ 0/1-PRA with } \mathcal{L}(\mathcal{P}_R) = \mathcal{L}(\mathcal{P})$$

**0/1-PRA**: Probabilistic **Rabin** Automaton s.t. all words have acceptance probability in  $\{0, 1\}$

# Complementation

## Theorem

For each PBA  $\mathcal{P}$  there exists a PBA  $\mathcal{P}'$  with  $|\mathcal{P}'| = \mathcal{O}(\exp(|\mathcal{P}|))$  such that  $\mathcal{L}(\mathcal{P}') = \Sigma^\omega \setminus \mathcal{L}(\mathcal{P})$ .  
 Moreover,  $\mathcal{P}'$  can be effectively constructed from  $\mathcal{P}$ .

## Proof Scheme

$$\begin{aligned} \mathcal{P} \text{ PBA} &\longrightarrow \mathcal{P}_R \text{ 0/1-PRA with } \mathcal{L}(\mathcal{P}_R) = \mathcal{L}(\mathcal{P}) \\ &\longrightarrow \mathcal{P}_S \text{ 0/1-PSA with } \mathcal{L}(\mathcal{P}_S) = \Sigma^\omega \setminus \mathcal{L}(\mathcal{P}_R) \end{aligned}$$

**0/1-PSA:** Probabilistic **Strett** Automaton s.t. all words have acceptance probability in  $\{0, 1\}$

# Complementation

## Theorem

For each PBA  $\mathcal{P}$  there exists a PBA  $\mathcal{P}'$  with  $|\mathcal{P}'| = \mathcal{O}(\exp(|\mathcal{P}|))$  such that  $\mathcal{L}(\mathcal{P}') = \Sigma^\omega \setminus \mathcal{L}(\mathcal{P})$ .  
 Moreover,  $\mathcal{P}'$  can be effectively constructed from  $\mathcal{P}$ .

## Proof Scheme

$$\begin{aligned} \mathcal{P} \text{ PBA} &\longrightarrow \mathcal{P}_R \text{ 0/1-PRA with } \mathcal{L}(\mathcal{P}_R) = \mathcal{L}(\mathcal{P}) \\ &\longrightarrow \mathcal{P}_S \text{ 0/1-PSA with } \mathcal{L}(\mathcal{P}_S) = \Sigma^\omega \setminus \mathcal{L}(\mathcal{P}_R) \\ &\longrightarrow \overline{\mathcal{P}} \text{ PBA with } \mathcal{L}(\overline{\mathcal{P}}) = \mathcal{L}(\mathcal{P}_S) \end{aligned}$$

# Complementation

## Theorem

For each PBA  $\mathcal{P}$  there exists a PBA  $\mathcal{P}'$  with  $|\mathcal{P}'| = \mathcal{O}(\exp(|\mathcal{P}|))$  such that  $\mathcal{L}(\mathcal{P}') = \Sigma^\omega \setminus \mathcal{L}(\mathcal{P})$ .  
 Moreover,  $\mathcal{P}'$  can be effectively constructed from  $\mathcal{P}$ .

## Proof Scheme

$\mathcal{P}$  PBA  $\longrightarrow$   $\mathcal{P}_R$  0/1-PRA with  $\mathcal{L}(\mathcal{P}_R) = \mathcal{L}(\mathcal{P})$   
 $\longrightarrow$   $\mathcal{P}_S$  0/1-PSA with  $\mathcal{L}(\mathcal{P}_S) = \Sigma^\omega \setminus \mathcal{L}(\mathcal{P}_R)$   
 $\longrightarrow$   $\overline{\mathcal{P}}$  PBA with  $\mathcal{L}(\overline{\mathcal{P}}) = \mathcal{L}(\mathcal{P}_S)$

**Difficult step:** PBA  $\longrightarrow$  equivalent 0/1-PRA

## Complementation: First step in details

- ▶ From  $\mathcal{P}$  build an equivalent 0/1-PRA.

**Construction idea:** Organize the infinite computation tree into a finite-state automaton by merging runs meeting at some point.

## Complementation: First step in details

- ▶ From  $\mathcal{P}$  build an equivalent 0/1-PRA.

**Construction idea:** Organize the infinite computation tree into a finite-state automaton by merging runs meeting at some point.

**States:** tuples  $\langle p_1, \xi_1, \dots, p_k, \xi_k, R \rangle$   
 $p_i \in Q$  pairwise distinct,  $\xi_i \in \{0, 1\}$  and  $R \subseteq Q$ .

- ▶  $R$ -component: usual powerset construction
- ▶  $p_i$  state witnessing sample runs
- ▶  $\xi_i$  bit indicating whether the last step is a proper  $\mathcal{P}$ -transition

## Complementation: First step in details

- ▶ From  $\mathcal{P}$  build an equivalent 0/1-PRA.

**Construction idea:** Organize the infinite computation tree into a finite-state automaton by merging runs meeting at some point.

**States:** tuples  $\langle p_1, \xi_1, \dots, p_k, \xi_k, R \rangle$   
 $p_i \in Q$  pairwise distinct,  $\xi_i \in \{0, 1\}$  and  $R \subseteq Q$ .

- ▶  $R$ -component: usual powerset construction
- ▶  $p_i$  state witnessing sample runs
- ▶  $\xi_i$  bit indicating whether the last step is a proper  $\mathcal{P}$ -transition

**Rabin condition:** for some index  $j$ , the  $j$ -th run visits  $F$  infinitely often and from some point on the attached bit is 0.

## Complementation: First step in details (2)

Possible  $a$ -successors of  $\bar{p} = \langle p_1, \xi_1, \dots, p_k, \xi_k, R \rangle$ :

$$\bar{q} = \langle q_1, \zeta_1, \dots, q_k, \zeta_k, q_{k+1}, \zeta_{k+1} \dots q_m, \zeta_m, S \rangle$$

1.  $q_i \in \delta(p_i, a)$  for  $1 \leq i \leq k$
2.  $\{q_{k+1}, \dots, q_m\} = (\delta(R, a) \cap F) \setminus \{q_1, \dots, q_k\}$
3.  $\zeta_1 = \dots = \zeta_k = 0$  and  $\zeta_{k+1} = \dots = \zeta_m = 1$
4.  $S = \delta(R, a)$

## Complementation: First step in details (2)

Possible  $a$ -successors of  $\bar{p} = \langle p_1, \xi_1, \dots, p_k, \xi_k, R \rangle$ :

$$\bar{q} = \langle q_1, \zeta_1, \dots, q_k, \zeta_k, q_{k+1}, \zeta_{k+1} \dots q_m, \zeta_m, S \rangle$$

1.  $q_i \in \delta(p_i, a)$  for  $1 \leq i \leq k$
2.  $\{q_{k+1}, \dots, q_m\} = (\delta(R, a) \cap F) \setminus \{q_1, \dots, q_k\}$
3.  $\zeta_1 = \dots = \zeta_k = 0$  and  $\zeta_{k+1} = \dots = \zeta_m = 1$
4.  $S = \delta(R, a)$

$$\mathbb{P}_{\text{PRA}}(\rho) > 0 \quad \Leftrightarrow \quad \mathbb{P}_{\text{PBA}}(\rho) > 0 \quad \Leftrightarrow \quad \mathbb{P}_{\text{PRA}}(\rho) = 1$$

## Complementation: First step in details (2)

Possible  $a$ -successors of  $\bar{p} = \langle p_1, \xi_1, \dots, p_k, \xi_k, R \rangle$ :

$$\bar{q} = \langle q_1, \zeta_1, \dots, q_k, \zeta_k, q_{k+1}, \zeta_{k+1} \dots q_m, \zeta_m, S \rangle$$

1.  $q_i \in \delta(p_i, a)$  for  $1 \leq i \leq k$
2.  $\{q_{k+1}, \dots, q_m\} = (\delta(R, a) \cap F) \setminus \{q_1, \dots, q_k\}$
3.  $\zeta_1 = \dots = \zeta_k = 0$  and  $\zeta_{k+1} = \dots = \zeta_m = 1$
4.  $S = \delta(R, a)$

$$\mathbb{P}_{\text{PRA}}(\rho) > 0 \quad \Leftrightarrow \quad \mathbb{P}_{\text{PBA}}(\rho) > 0 \quad \Leftrightarrow \quad \mathbb{P}_{\text{PRA}}(\rho) = 1$$

Example

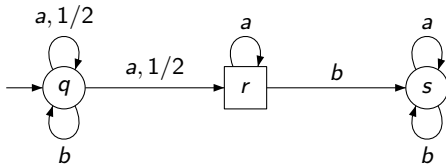

$$\mathcal{L}(\mathcal{P}) = (a + b)^* a^\omega$$

## Complementation: First step in details (3)

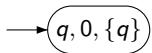

## Complementation: First step in details (3)

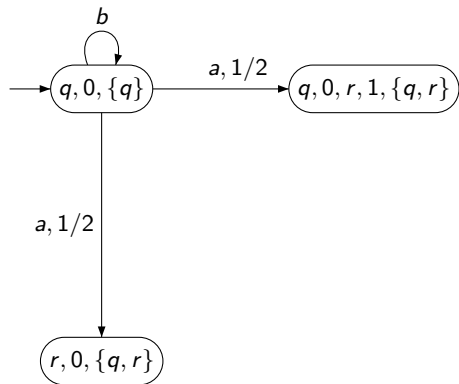

## Complementation: First step in details (3)

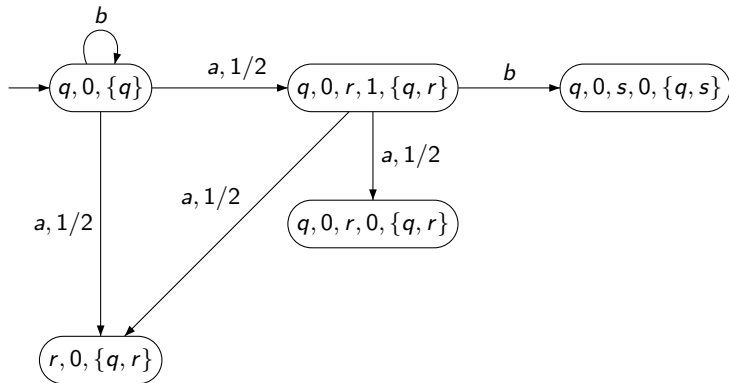

## Complementation: First step in details (3)

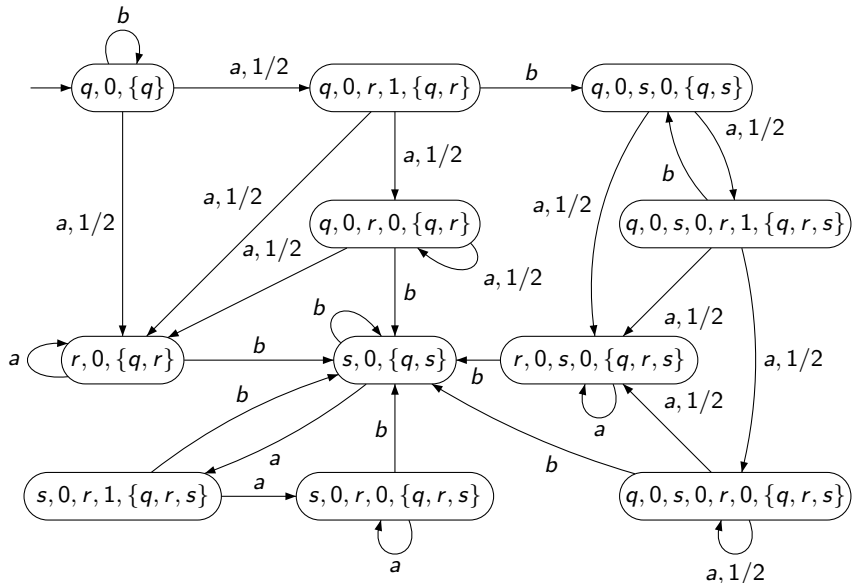

## Complementation: First step in details (3)

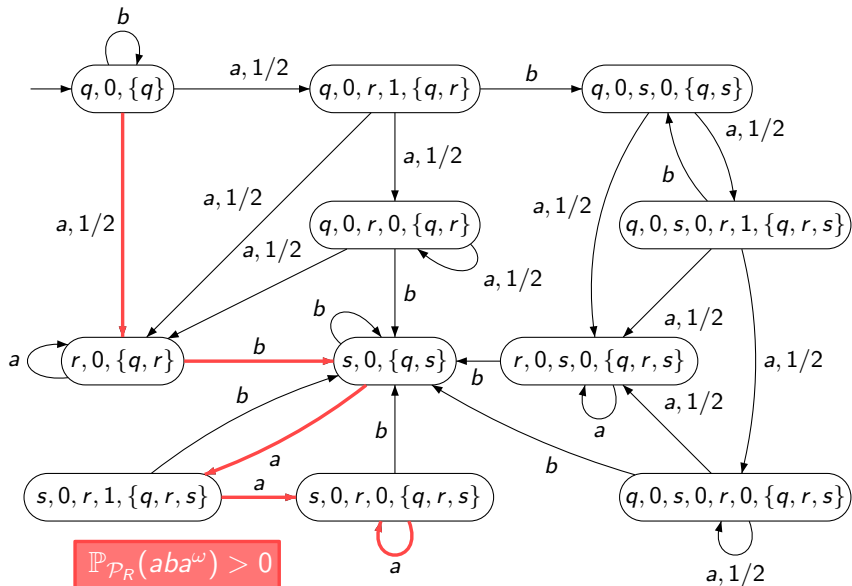

## Complementation: First step in details (3)

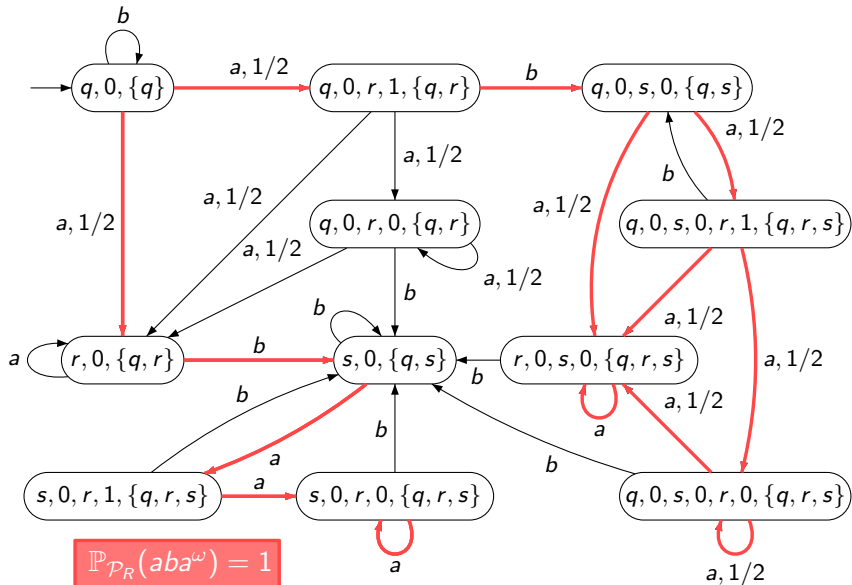

# Outline

- 1 Introduction
- 2 Complementation
- 3 Emptiness problem**
  - Langage dependency on probabilities
  - Undecidability of emptiness
- 4 Alternative semantics
  - Expressivity
  - Emptiness problem
- 5 Conclusion

## A weird example

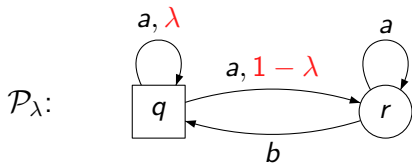

$$\mathcal{L}(\mathcal{P}_\lambda) = \{a^{k_1} b a^{k_2} b \dots \mid \prod_i (1 - \lambda^{k_i}) > 0\}$$

## A weird example

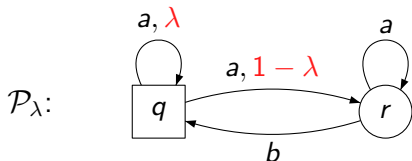

$$\mathcal{L}(\mathcal{P}_\lambda) = \{a^{k_1} b a^{k_2} b \dots \mid \prod_i (1 - \lambda^{k_i}) > 0\}$$

### Lemma

For  $0 < \lambda < \frac{1}{2} < \mu < 1$ ,  $\mathcal{L}(\mathcal{P}_\lambda) \neq \mathcal{L}(\mathcal{P}_\mu)$ .

**Hint**  $w = a^{k_1} b a^{k_2} b \dots$  with for all  $m$ ,  $2^m$  elements of  $(k_i)$  set to  $m$ .  
 $\longrightarrow w \in \mathcal{L}(\mathcal{P}_\lambda) \setminus \mathcal{L}(\mathcal{P}_\mu)$

## An undecidable problem for PFA

The emptiness problem is **undecidable** for Probabilistic Finite Automata (as well as some variants).

## An undecidable problem for PFA

The emptiness problem is **undecidable** for Probabilistic Finite Automata (as well as some variants).

### Undecidability result for PFA [MHC03]

The following problem is undecidable:

Given  $0 < \varepsilon < 1$  and  $\mathcal{P}$  a PFA such that

- ▶ either  $\exists w \mathbb{P}_{\mathcal{P}}(w) > 1 - \varepsilon$
- ▶ or  $\forall w \mathbb{P}_{\mathcal{P}}(w) \leq \varepsilon$

tell which is the case.

# Emptiness problem for PBA

## Theorem

The emptiness problem is undecidable for PBA.

# Emptiness problem for PBA

## Theorem

The emptiness problem is undecidable for PBA.

## Proof Sketch

**Reduction** of the modified emptiness problem for PFA

# Emptiness problem for PBA

## Theorem

The emptiness problem is undecidable for PBA.

## Proof Sketch

**Reduction** of the modified emptiness problem for PFA

$$\mathcal{R} \text{ PFA with } \begin{cases} \forall w \mathbb{P}_{\mathcal{R}}(w) \leq \varepsilon & \text{or} \\ \exists w \mathbb{P}_{\mathcal{R}}(w) > 1 - \varepsilon \end{cases}$$

$$\downarrow$$

$\mathcal{P}_1$  and  $\mathcal{P}_2$  PBA s.t.

$$\mathcal{L}^{>\varepsilon}(\mathcal{R}) = \emptyset \iff \mathcal{L}(\mathcal{P}_1) \cap \mathcal{L}(\mathcal{P}_2) = \emptyset$$

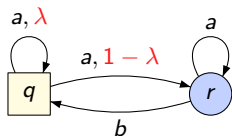
Proof in more details:  $\mathcal{P}_1$ 

$$\mathcal{L}(\mathcal{P}_\lambda) = \{a^{k_1} b a^{k_2} b \dots \mid \prod_i (1 - \lambda^{k_i}) > 0\}$$

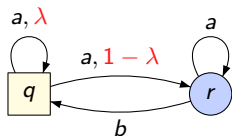
Proof in more details:  $\mathcal{P}_1$ 

$$\mathcal{L}(\mathcal{P}_\lambda) = \{a^{k_1} b a^{k_2} b \dots \mid \prod_i (1 - \lambda^{k_i}) > 0\}$$

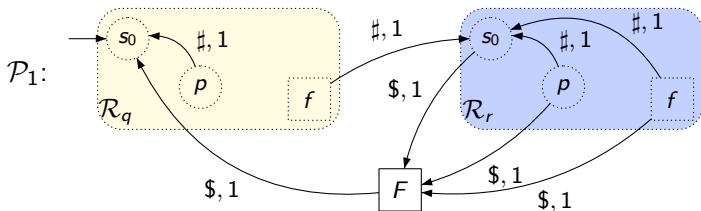

From  $s_0$  in  $\mathcal{R}_q$ , reading  $w\#$  leads to  $\mathcal{R}_r$  with probability  $\mathbb{P}_{\mathcal{R}}(w)$ .

$$a \longrightarrow w \quad \lambda \longrightarrow 1 - \mathbb{P}_{\mathcal{R}}(w) \quad b \longrightarrow \$$$$

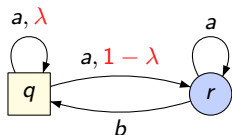
Proof in more details:  $\mathcal{P}_1$ 

$$\mathcal{L}(\mathcal{P}_\lambda) = \{a^{k_1} b a^{k_2} b \dots \mid \prod_i (1 - \lambda^{k_i}) > 0\}$$

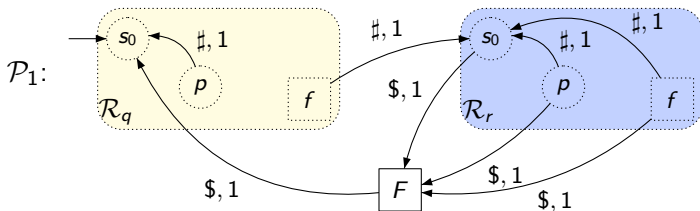

From  $s_0$  in  $\mathcal{R}_q$ , reading  $w\#$  leads to  $\mathcal{R}_r$  with probability  $\mathbb{P}_{\mathcal{R}}(w)$ .  
 $a \longrightarrow w \quad \lambda \longrightarrow 1 - \mathbb{P}_{\mathcal{R}}(w) \quad b \longrightarrow \$\$$

$$\mathcal{L}(\mathcal{P}_1) = \{w_1^1 \# \dots w_{k_1}^1 \$\$ w_1^2 \# \dots w_{k_2}^2 \$\$ \dots \mid \prod_j \left(1 - \left(\prod_{i=1}^{k_j-1} (1 - \mathbb{P}_{\mathcal{R}}(w_i^j))\right)\right) > 0\}$$

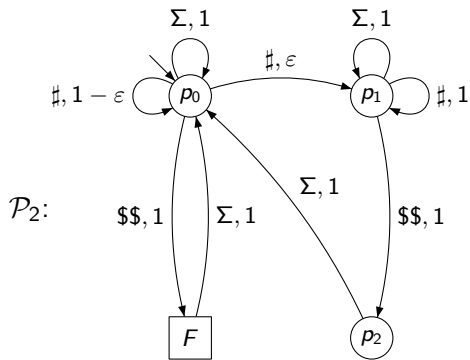
Proof in more details:  $\mathcal{P}_2$ 

From  $p_0$ , reading  $v \in (\Sigma \cup \{\#\})^*$  leads to  $p_1$   
with probability  $1 - (1 - \varepsilon)^{|v|_{\#}}$

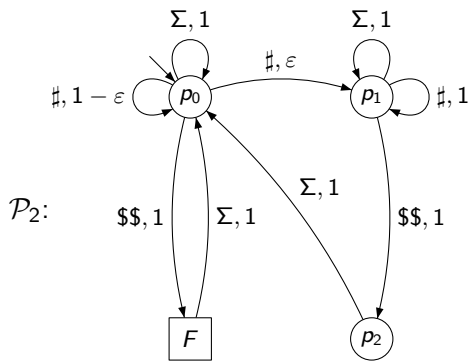
Proof in more details:  $\mathcal{P}_2$ 

From  $p_0$ , reading  $v \in (\Sigma \cup \{\#\})^*$  leads to  $p_1$   
with probability  $1 - (1 - \varepsilon)^{|v|_{\#}}$

$$\mathcal{L}(\mathcal{P}_2) = \{v_1 \$\$ v_2 \$\$ \dots \mid v_i \in (\Sigma \cup \{\#\})^* \text{ and } \prod_i (1 - (1 - \varepsilon)^{|v_i|_{\#}}) = 0\}$$

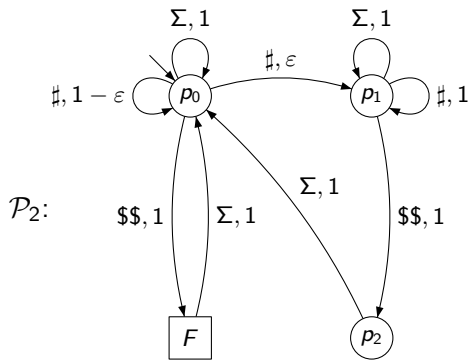
Proof in more details:  $\mathcal{P}_2$ 

From  $p_0$ , reading  $v \in (\Sigma \cup \{\#\})^*$  leads to  $p_1$   
with probability  $1 - (1 - \varepsilon)^{|v|_{\#}}$

$$\mathcal{L}(\mathcal{P}_2) = \{w_1^1 \# \cdots w_{k_1}^1 \$\$ w_1^2 \# \cdots w_{k_2}^2 \$\$ \cdots \mid \prod_i (1 - (1 - \varepsilon)^{k_i - 1}) = 0\}$$

## Proof conclusion

- $\mathcal{L}(\mathcal{P}_1) = \{w_1^1 \# \cdots w_{k_1}^1 \$\$ w_1^2 \# \cdots w_{k_2}^2 \$\$ \cdots \mid \prod_j \left( 1 - \left( \prod_{i=1}^{k_j-1} (1 - \mathbb{P}_{\mathcal{R}}(w_i^j)) \right) \right) > 0 \}$
- $\mathcal{L}(\mathcal{P}_2) = \{w_1^1 \# \cdots w_{k_1}^1 \$\$ w_1^2 \# \cdots w_{k_2}^2 \$\$ \cdots \mid \prod_i (1 - (1 - \varepsilon)^{k_i-1}) = 0 \}$

## Proof conclusion

- $\mathcal{L}(\mathcal{P}_1) = \{w_1^1 \# \dots w_{k_1}^1 \$\$ w_1^2 \# \dots w_{k_2}^2 \$\$ \dots \mid \prod_j \left( 1 - \left( \prod_{i=1}^{k_j-1} (1 - \mathbb{P}_{\mathcal{R}}(w_i^j)) \right) \right) > 0 \}$
- $\mathcal{L}(\mathcal{P}_2) = \{w_1^1 \# \dots w_{k_1}^1 \$\$ w_1^2 \# \dots w_{k_2}^2 \$\$ \dots \mid \prod_i (1 - (1 - \varepsilon)^{k_i-1}) = 0 \}$

If  $\forall w, \mathbb{P}_{\mathcal{R}}(w) \leq \varepsilon$

$\forall \tilde{w}, \tilde{w} \in \mathcal{L}(\mathcal{P}_2) \Rightarrow \tilde{w} \notin \mathcal{L}(\mathcal{P}_1)$

$\Rightarrow \mathcal{L}(\mathcal{P}_1) \cap \mathcal{L}(\mathcal{P}_2) = \emptyset$

## Proof conclusion

- $\mathcal{L}(\mathcal{P}_1) = \{w_1^1 \# \dots w_{k_1}^1 \$\$ w_1^2 \# \dots w_{k_2}^2 \$\$ \dots \mid \prod_j (1 - (\prod_{i=1}^{k_j-1} (1 - \mathbb{P}_{\mathcal{R}}(w_i^j)))) > 0\}$
- $\mathcal{L}(\mathcal{P}_2) = \{w_1^1 \# \dots w_{k_1}^1 \$\$ w_1^2 \# \dots w_{k_2}^2 \$\$ \dots \mid \prod_i (1 - (1 - \varepsilon)^{k_i-1}) = 0\}$

If  $\forall w, \mathbb{P}_{\mathcal{R}}(w) \leq \varepsilon$

$\forall \tilde{w}, \tilde{w} \in \mathcal{L}(\mathcal{P}_2) \Rightarrow \tilde{w} \notin \mathcal{L}(\mathcal{P}_1)$

$\Rightarrow \mathcal{L}(\mathcal{P}_1) \cap \mathcal{L}(\mathcal{P}_2) = \emptyset$

If  $\exists w, \mathbb{P}_{\mathcal{R}}(w) > 1 - \varepsilon$

Let  $\tilde{w} = (w\#)^{k_1} w \$\$ (w\#)^{k_2} w \$\$ \dots$

$\mathbb{P}_{\mathcal{P}_1}(\tilde{w}) > \prod_j (1 - \varepsilon^{k_j-1})$  and  $\mathbb{P}_{\mathcal{P}_2}(\tilde{w}) = \prod_i (1 - (1 - \varepsilon)^{k_i-1})$

$\Rightarrow \mathcal{L}(\mathcal{P}_1) \cap \mathcal{L}(\mathcal{P}_2) \neq \emptyset$

## Proof conclusion

- $\mathcal{L}(\mathcal{P}_1) = \{w_1^1 \# \dots w_{k_1}^1 \$\$ w_1^2 \# \dots w_{k_2}^2 \$\$ \dots \mid \prod_j (1 - (\prod_{i=1}^{k_j-1} (1 - \mathbb{P}_{\mathcal{R}}(w_i^j)))) > 0\}$
- $\mathcal{L}(\mathcal{P}_2) = \{w_1^1 \# \dots w_{k_1}^1 \$\$ w_1^2 \# \dots w_{k_2}^2 \$\$ \dots \mid \prod_i (1 - (1 - \varepsilon)^{k_i-1}) = 0\}$

If  $\forall w, \mathbb{P}_{\mathcal{R}}(w) \leq \varepsilon$

$\forall \tilde{w}, \tilde{w} \in \mathcal{L}(\mathcal{P}_2) \Rightarrow \tilde{w} \notin \mathcal{L}(\mathcal{P}_1)$

$\Rightarrow \mathcal{L}(\mathcal{P}_1) \cap \mathcal{L}(\mathcal{P}_2) = \emptyset$

If  $\exists w, \mathbb{P}_{\mathcal{R}}(w) > 1 - \varepsilon$

Let  $\tilde{w} = (w\#)^{k_1} w \$\$ (w\#)^{k_2} w \$\$ \dots$

$\mathbb{P}_{\mathcal{P}_1}(\tilde{w}) > \prod_j (1 - \varepsilon^{k_j-1})$  and  $\mathbb{P}_{\mathcal{P}_2}(\tilde{w}) = \prod_i (1 - (1 - \varepsilon)^{k_i-1})$

$\Rightarrow \mathcal{L}(\mathcal{P}_1) \cap \mathcal{L}(\mathcal{P}_2) \neq \emptyset$

$$\mathcal{L}^{>\varepsilon}(\mathcal{R}) = \emptyset \Leftrightarrow \mathcal{L}(\mathcal{P}_1) \cap \mathcal{L}(\mathcal{P}_2) = \emptyset$$

# PBA-related Consequences

Immediate consequences of the undecidability result.

## Corollary

The following problems are undecidable. Given  $\mathcal{P}_1$  and  $\mathcal{P}_2$  PBA

- $\mathcal{L}(\mathcal{P}_1) = \Sigma^\omega$  ?
- $\mathcal{L}(\mathcal{P}_1) = \mathcal{L}(\mathcal{P}_2)$  ?
- $\mathcal{L}(\mathcal{P}_1) \subseteq \mathcal{L}(\mathcal{P}_2)$  ?

# PBA-related Consequences

Immediate consequences of the undecidability result.

## Corollary

The following problems are undecidable. Given  $\mathcal{P}_1$  and  $\mathcal{P}_2$  PBA

- $\mathcal{L}(\mathcal{P}_1) = \Sigma^\omega$  ?
- $\mathcal{L}(\mathcal{P}_1) = \mathcal{L}(\mathcal{P}_2)$  ?
- $\mathcal{L}(\mathcal{P}_1) \subseteq \mathcal{L}(\mathcal{P}_2)$  ?

## Verification against PBA specifications

The following problems are undecidable. Given a transition system  $T$  and a PBA  $\mathcal{P}$

- ▶ is there a path in  $T$  whose trace is in  $\mathcal{L}(\mathcal{P})$  ?
- ▶ do the traces of all paths in  $T$  belong to  $\mathcal{L}(\mathcal{P})$  ?

# Consequences for POMDP

## Partially Observable MDP

A POMDP  $(\mathcal{M}, \sim)$  consists of an MDP  $\mathcal{M}$  equipped with an equivalence relation  $\sim$  over states of  $\mathcal{M}$ .

# Consequences for POMDP

## Partially Observable MDP

A POMDP  $(\mathcal{M}, \sim)$  consists of an MDP  $\mathcal{M}$  equipped with an equivalence relation  $\sim$  over states of  $\mathcal{M}$ .

## Undecidability results

The following problems are undecidable

- ▶ Given  $(\mathcal{M}, \sim)$  and  $F$  set of states of  $\mathcal{M}$ , is there an observation-based  $\mathcal{U}$  such that  $\mathbb{P}_{\mathcal{U}}(\Box\Diamond F) > 0$ .
- ▶ Given  $(\mathcal{M}, \sim)$  and  $F$  set of states of  $\mathcal{M}$ , is there an observation-based  $\mathcal{U}$  such that  $\mathbb{P}_{\mathcal{U}}(\Diamond\Box F) = 1$ .

# Consequences for POMDP

## Partially Observable MDP

A POMDP  $(\mathcal{M}, \sim)$  consists of an MDP  $\mathcal{M}$  equipped with an equivalence relation  $\sim$  over states of  $\mathcal{M}$ .

## Undecidability results

The following problems are undecidable

- ▶ Given  $(\mathcal{M}, \sim)$  and  $F$  set of states of  $\mathcal{M}$ , is there an observation-based  $\mathcal{U}$  such that  $\mathbb{P}_{\mathcal{U}}(\Box\Diamond F) > 0$ .
- ▶ Given  $(\mathcal{M}, \sim)$  and  $F$  set of states of  $\mathcal{M}$ , is there an observation-based  $\mathcal{U}$  such that  $\mathbb{P}_{\mathcal{U}}(\Diamond\Box F) = 1$ .

First undecidability results in qualitative verification of POMDP.

# Outline

- 1 Introduction
- 2 Complementation
- 3 Emptiness problem
  - Language dependency on probabilities
  - Undecidability of emptiness
- 4 **Alternative semantics**
  - Expressivity
  - Emptiness problem
- 5 Conclusion

# Almost-sure semantics for PBA

## Alternative semantics

$$L(\mathcal{A}) = \{w \in \Sigma^\omega \mid \mathbb{P}_{\mathcal{A}}(\{\rho \in \text{Runs}(w) \mid \rho \models \Box\Diamond F\}) = 1\}$$

# Almost-sure semantics for PBA

## Alternative semantics

$$L(\mathcal{A}) = \{w \in \Sigma^\omega \mid \mathbb{P}_{\mathcal{A}}(\{\rho \in \text{Runs}(w) \mid \rho \models \Box\Diamond F\}) = 1\}$$

## Expressivity

- ▶ almost-sure PBA are strictly less expressive than PBA
- ▶ almost-sure PBA and  $\omega$ -regular languages are incomparable
- ▶ almost-sure PBA are not closed under complementation

## Recap: expressivity

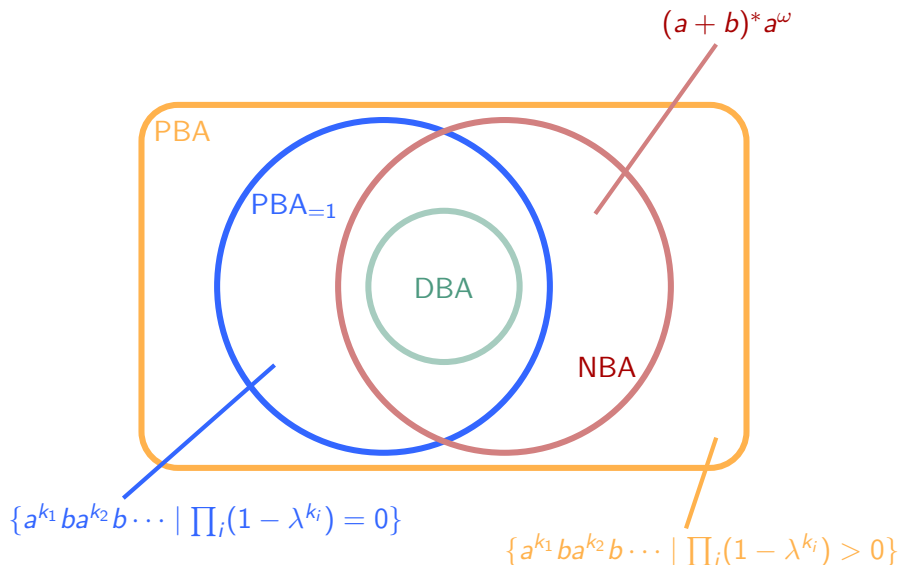

# Emptiness problem and related results

## Decidability result for POMDP

Almost-sure reachability in POMDP is decidable (EXPTIME).

# Emptiness problem and related results

## Decidability result for POMDP

Almost-sure reachability in POMDP is decidable (EXPTIME).

## Corollary

The emptiness problem is decidable for almost-sure PBA.

## Proof Sketch

- ▶ for PBA almost-sure reachability and almost-sure repeated reachability are interreducible
- ▶ PBA are a special instance of POMDP

# Outline

- 1 Introduction
- 2 Complementation
- 3 Emptiness problem
  - Langage dependency on probabilities
  - Undecidability of emptiness
- 4 Alternative semantics
  - Expressivity
  - Emptiness problem
- 5 Conclusion

# Conclusion

## Results concerning PBA

- ▶ complementation operator
- ▶ emptiness (and related problems) undecidable for PBA
- ▶ expressivity of almost-sure PBA
- ▶ emptiness decidable for almost-sure PBA

# Conclusion

## Results concerning PBA

- ▶ complementation operator
- ▶ emptiness (and related problems) undecidable for PBA
- ▶ expressivity of almost-sure PBA
- ▶ emptiness decidable for almost-sure PBA

## Results concerning POMDP

- ▶ positive repeated reachability undecidable for POMDP
- ▶ almost-sure reachability decidable for POMDP

# Conclusion

## Results concerning PBA

- ▶ complementation operator
- ▶ emptiness (and related problems) undecidable for PBA
- ▶ expressivity of almost-sure PBA
- ▶ emptiness decidable for almost-sure PBA

## Results concerning POMDP

- ▶ positive repeated reachability undecidable for POMDP
- ▶ almost-sure reachability decidable for POMDP

## Open questions

- ▶ emptiness problem for PBA with small alphabet
- ▶ efficient transformation from LTL to PBA

Thank you for your attention!



Questions?