

An hybrid explicit multicast/recursive unicast approach for multicast routing

Ali Boudani*, Bernard Cousin

IRISA/INRIA, Campus de Beaulieu, 35 042 Rennes Cedex, France

Received 2 July 2003; revised 22 February 2005; accepted 22 February 2005

Available online 23 March 2005

Abstract

In this paper, we propose a new approach, Simple Explicit Multicast (SEM), which uses an efficient method to construct multicast trees and to deliver multicast packets to all destinations. In order to construct a multicast tree, the source encodes the list of destination addresses in a *branch* message. This message discovers the tree branching routers and creates a multicast routing state in each of these routers. For multicast packets delivery, it uses recursive unicast trees where packets travel from a branching router to another following the tree constructed by the *branch* message.

© 2005 Elsevier B.V. All rights reserved.

Keywords: Multicast; IP; Routing protocol; Explicit multicast

1. Introduction

Multicast has become increasingly important with the emergence of network-based applications that consume a large amount of network bandwidth such as video conferencing, distributed interactive simulation (DIS) and software upgrading. Using multicast services, a single transmission is needed for sending a packet to n destinations by sharing the link bandwidth, while n independent transmissions would be required using unicast services. But, multicast suffers from a scalability problem. Indeed, a multicast router should keep a routing state for every multicast tree passing through it and the number of routing states grows with the number of groups.

Recently, significant research effort has focused on the multicast scalability problem. Some schemes attempt to reduce the number of routing states by tunneling [1] or by routing states aggregation [2]. Both these works attempt to aggregate routing states after these have been allocated to groups. It is assumed that underlying multicast protocols such as PIM-SM [3] or CBT [4] already exists in all routers

in the network. Other architectures aim to eliminate routing states at routers either completely by explicitly encoding the list of destinations in packets, instead of using a multicast address (Xcast [5], GXcast [6]) or partially by using branching routers in the multicast tree (REUNITE [7], SEM, HBH [8]). It should be noted that the HBH protocol tried to eliminate routing states (called multicast forwarding tables MFT) from nonbranching routers while conserving control states (called multicast control tables MCT) in these routers. But as we will see later in this paper, nonbranching routers in HBH may still have multicast routing state.

This document describes a new approach, Simple Explicit Multicast (SEM), which uses an efficient method to construct multicast trees and deliver multicast packets. In order to construct the multicast tree, the source encodes the list of destination addresses in a *branch* message which has a role to discover routers acting as branching nodes in the multicast tree. We mean by branching router, a router where packets arrive in an interface and should be forwarded to multiple interfaces (according to the next hop toward the destination routers). A special control plane is introduced to inform each branching router about its next and previous hop branching routers for a group. Instead, for multicast packets delivery, packets will travel from a branching router to another following the tree constructed by the *branch* message. We propose that the source uses unicast encoding for multicast packets and sends them to its next hop

* Corresponding author. Tel.: +33 2 9984 2537; fax: +33 2 9984 2529.
E-mail addresses: aboundani@irisa.fr (A. Boudani), cousin@irisa.fr (B. Cousin).

branching routers. Each branching router acts as a source and packets travel from a branching router to another.

The remainder of this paper is organized as follows. In Section 2, we present some related works. In Section 3, we describe SEM and we discuss some related issues. In Section 4, we present the tree management mechanisms for the three protocols REUNITE, HBH and SEM. We also compare SEM to HBH and we discuss the type of a *branch* message in both protocols. Sections 5 and 6 contain SEM analysis, evaluation and simulation. Section 7 is a summary followed by a list of references.

2. Related work

In this section, we present some of our proposal related works: Tunneling [1], State aggregation [2], Explicit Multicast [5], REUNITE [7] and HBH [8].

2.1. Tunneling and state aggregation

In [1], the underlying multicast protocol is used to construct dynamic tunnels. Besides, a router interface can operate in dual mode where two copies of the same packet will be sent at the same time in native and tunnel mode. In [2], leaky multicast addresses aggregation was studied. A packet that matches the resulting forwarding entry will be forwarded on all interfaces on which join messages have been received, but it may be forwarded on some other interfaces as well (those for which no join message was received). In SEM, there is no need for underlying multicast routing protocols (that use generally the reverse path forwarding) to construct multicast trees. *branch* message constructs the shortest path tree from the source to all destinations and thus only one copy of packet is sent through this shortest path from a branching router to another.

2.2. Explicit multicast

Explicit Multicast (Xcast) [5] is a newly proposed multicast scheme to support a very large number of small multicast groups. It explicitly encodes the list of destinations in packets, instead of using a multicast address. Thus, the source encodes the list of destinations in the Xcast header, and then sends the packet to a router. Each router along the way parses the header, partitions the destinations based on each destination's next hop, and forwards a packet with an appropriate Xcast header to each of the next hops. An increased header processing per packet is cumbersome for high link speeds.

Xcast+ [9] is an extension of Xcast for a more efficient delivery of multicast packets. Every source or destination is associated to a Designated Router (DR). Instead of encoding in the Xcast packet header the set of group members, Xcast+ encodes the set of their DR. When a new member wants to join the group G of source S , it sends an IGMP [10]

join message to its DR. The DR will send a join-request message to the source S . The DR of the source intercepts this message and analyzes it in order to keep track of all concerned DR addresses. When the source S wants to send a message to the group G , it sends a multicast packet. This packet is received by its DR and converted to an Xcast packet using the Multicast-to-Xcast algorithm (M2X). The packet is then forwarded as in Xcast to all DR destinations, since the destination list in the Xcast header contains the DR addresses instead of the member addresses. Then, each DR converts the Xcast packet to a multicast packet using the Xcast-to-Multicast protocol (X2M) and sends it in its subnetworks. Whereas Xcast can support a very large number of small multicast groups, Xcast+ can support a very large number of medium size multicast groups.

In [6] we proposed GXcast: a simple generalized version of the Xcast and the Xcast+ protocols. Indeed, instead of sending a message to n destinations, the source limits the number of destinations in a packet to n_M . Thus, the list of n destinations is cutted into sub-lists of at most n_M destinations. Each sub-list corresponds to a destination list for an Xcast packet. Several packets may have to be sent in order to deliver data to all the n destinations. GXcast packets are similar to Xcast packets: they have the same header and are treated the same way by intermediate routers, by DR destinations and by receivers destinations. The only difference between the Xcast protocol and the GXcast protocol is done in the DR of the source. The Xcast protocol and the GXcast protocol can therefore inter-operate easily.

In all these newly proposed protocols the source (the terms source and DR of the source are used undistinctly) knows the addresses of all the destinations before sending packets. The header processing time in every router grows with the number of the DR. The major difference between GXcast for example and SEM is that Xcast+ encodes the list of destinations in each packet while SEM uses this mechanism only with the *branch* message. In both protocols the packet follows the unicast path between the source and all destinations. In SEM the packet will travel from a branching router to another following the same unicast path. This seems a good solution in order to optimize the packet header processing time in every router.

2.3. REUNITE and HBH

REUNITE [7] and HBH [8], use recursive unicast trees to implement multicast service. REUNITE does not use class D IP addresses. Instead, both group identification and data forwarding are based on unicast IP addresses. Only branching routers for a group need to keep multicast routing state. All other nonbranching routers keep only multicast control state and simply forward data packets by unicast routing.

The HBH multicast routing protocol attempted to solve some problems in REUNITE. First, HBH uses class D IP addresses for multicast channels and not a unicast addresses as in REUNITE. Second, in REUNITE, when the first router

that has previously joined a group leaves the group, the tree maintenance becomes very complicated. Third, HBH attempted to resolve the asymmetric routing problem present in REUNITE. Finally, an HBH router keeps only the next hop router addresses and not the first router that join the channel (multicast control table (MCT) and multicast forwarding table (MFT) have been modified).

SEM (same as HBH) uses the unicast infrastructure to forward packets as REUNITE does but uses (S, G) channels with class-D IP addresses to identify multicast channels. Using the IP multicast addressing model preserves compatibility with conventional multicast protocols. Since SEM uses the multicast addresses, The SEM control plane is compatible with the existing multicast protocols. SEM solves also the asymmetric routing problem present in REUNITE since it uses the shortest path tree from the source to destinations. Besides, SEM eliminate all MCT and MFT entries in nonbranching routers. In Section 3, we describe SEM and we compare it to HBH in Section 4.

3. Simple explicit multicast protocol

In order to simplify address allocation in SEM, a source creates and advertises a multicast channel (S, G) where S is the source unicast address and G is a standard group multicast address. Special multicast address range can be used to identify and differentiate easily SEM channels from conventional multicast channels. To build a multicast tree,¹ SEM uses two messages: *branch* and *previous_branch*. Moreover, SEM uses an *alive* message to maintain the multicast tree. A destination joins the tree and leaves it with source specific *join* and *leave* messages which always reach the source. These two messages are identical to those used for the SSM protocol [11,12]. Only the tree branching routers keep a routing state for the multicast channel (S, G) in their multicast routing table (called hereafter TRM). $TRM(S, G)$ (cf. Fig. 1) represents the entry associated with the channel (S, G) in TRM. Entries in each $TRM(S, G)$ are S , the source address, G , the group address, p_B , the previous branching router address on the tree, and the addresses of the next branching routers on the tree.

3.1. Receiver and router considerations

A receiver wishing to subscribe to an (S, G) channel sends IGMP *join* message destined to this channel. When receiving this message, the designated router (called hereafter DR) associated to the receiver subnet sends source specific *join(S, G)* message directly to the source S . When the source receives this message, it maintains in a multicast control table (TCM) the list of addresses (L) of all DR routers having receivers belonging to the (S, G) channel.

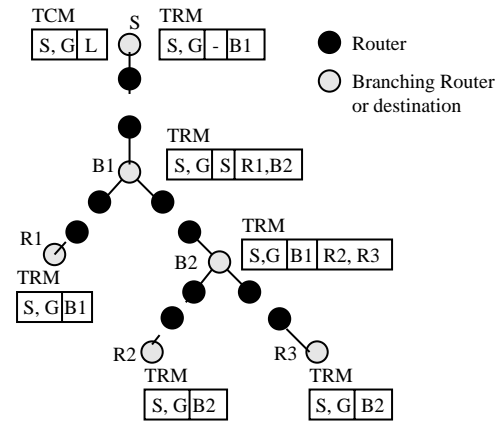

Fig. 1. Multicast routing tables (TRM).

$TCM(S, G)$ (cf. Fig. 1) represents the entry associated with the channel (S, G) in TCM. Entries in each (S, G) are S , the source address, G , the group address, and the list L .

Intermediate routers do not need to keep a routing state or a control state for the channel (S, G) . Thus, it is necessary that the DR routers associated with receivers know the source address and the previous branching router address for that channel. Current version of IGMP, IGMPv3 [10] supports source discovery and source specific host membership report. That is, SEM receivers do not use additional control to join SEM channels: they use IGMP.

For gradual implementation in networks, SEM can use for its *branch* message the IPv6 Hop-by-Hop option as described in the basic specification of Xcast [5]. One domain can then implement SEM while other domains may implement conventional multicast routing protocols.

Fig. 2 describes the join process of a receiver to a channel (S, G) . The receiver subscribes to the channel (S, G) by sending an IGMP *join* message to the DR of its local area network (1 and 2 in Fig. 2). The DR receives this IGMP *join* message and sends to the source a source specific *join(S, G)* message (3 and 4 in Fig. 2). When receiving this message, the source adds the address of the DR to the list L for the channel (S, G) ² (5 and 6 in Fig. 2).

The SEM protocol uses *alive* messages between branching routers to maintain the tree. The *alive* messages are periodically sent in unicast by the receivers (the DR of the local area network of the receivers) towards the previous branching router on the tree. This message is used to refresh the routing state in this router. A router B which receives from the router R an *alive(S, G, R)*³ destined to it refreshes the entry which corresponds to R in its multicast routing table $TRM(S, G)$ (this entry is called hereafter $TRM(S, G).R$). The *alive(S, G, R)* message is discarded and a new *alive(S, G, B)* message is sent to the previous branching router. The periodic *alive(S, G, B)* message, is used for

² If no list exists for the channel (S, G) , a new list is created.

³ *alive(S, G, R)* indicates the alive message sent in unicast by the router R towards the previous branching router for the channel (S, G) .

¹ A multicast tree is formed from branching routers only.

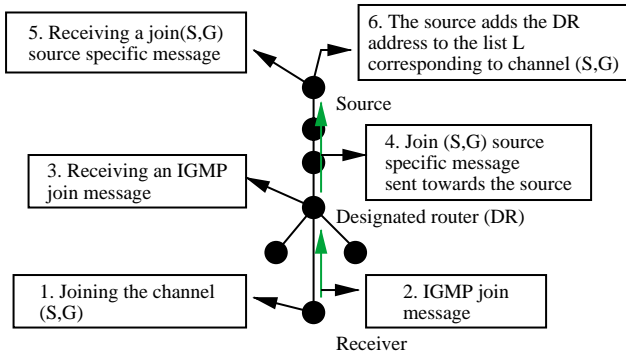

Fig. 2. Joining the channel (S, G) in SEM.

the maintenance of the tree and does not occur directly after the discard of the *alive(S, G, R)* message.

3.2. SEM tree construction and packet delivery

In SEM, the source keeps track of the DR routers addresses that have sent source specific *join* messages for a multicast channel (S, G). The source encodes the list L of these DR addresses in a SEM header of a *branch* message. The source parses the header, partitions the destinations into sublists (L_i) according to their next unicast hop router, and forwards a *branch* message with an appropriate SEM header to each of the next hop routers. Each router along the path to DR destinations repeats the same processing on receiving a *branch* message. The role of the *branch* message is to discover the multicast tree branching routers. Fig. 3 describes the *branch*⁴ message processing in a SEM router.

When this *branch* message reaches a nonbranching router for a channel (S, G), it is forwarded unchanged to the unique next hop router for all destinations. Otherwise, it checks the presence of an entry in the routing table corresponding to the channel (S, G). If $TRM(S, G)$ exists, this entry is updated.⁵ If no entry exists, a new entry is created at this branching router. The entry contains the source address, the multicast address for the group, the previous branching router address and the list of addresses of the next hop branching routers (the list is initially empty). The branching router replaces the value of the previous branching router of the new *branch* message header with its own address. In both cases, the router sends *branch* messages for all the lists L_i .

The branching router sends also a *previous_branch* message towards the previous branching router (the address is deduced from the *branch* message). Fig. 4 describes the processing of a *previous_branch*⁶ message in a SEM router.

The *previous_branch* message received by the previous branching router updates the state corresponding to

⁴ $branch(S, G, p_B, L)$ indicates the *branch* message for the list L corresponding to the channel (S, G) sent by the router p_B .

⁵ $TRM(S, G)$ is initialized as empty.

⁶ $previous_branch(B, p_B, S, G)$ indicates the *previous_branch* message for the channel (S, G) sent by the router B to the router p_B .

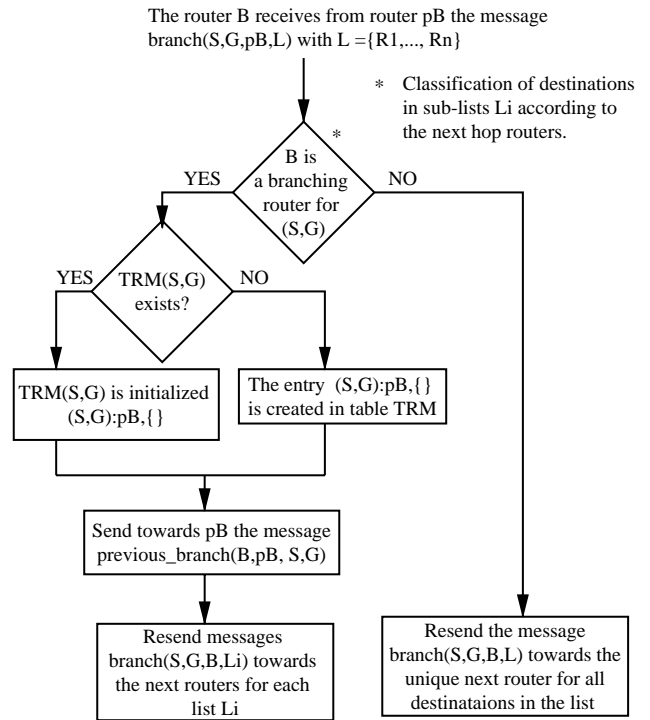

Fig. 3. *branch* message processing in a SEM router.

the channel (S, G). Thus, this message informs the previous branching router about its next branching routers. At the end of this operation, we obtain a path from the source towards each DR by using the addresses of the next branching routers. Thus, the source can send data packets to the various receivers of the channel (S, G).

Example. Consider the network represented in Fig. 1 and the group G formed from the source S and the six destinations A, B, C, D, E and F. A, B, C, D, E and F generate IGMP *join* messages to the DR associated to their sub-networks. When receiving the IGMP messages, R4, R8 and R9 each sends a source specific *join* message to the source S. Then, S sends a *branch* message to R1 with the list of multicast routers (R4, R8 and R9) in its SEM header. The IP header of the *branch* message sent by S to R1 contains: the source address S and the group address G. The SEM header of the *branch* message

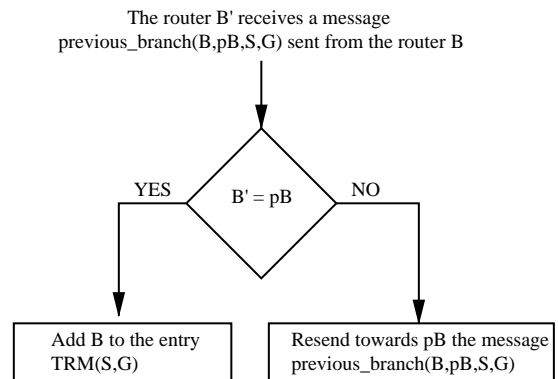

Fig. 4. *previous_branch* message processing in a SEM router.

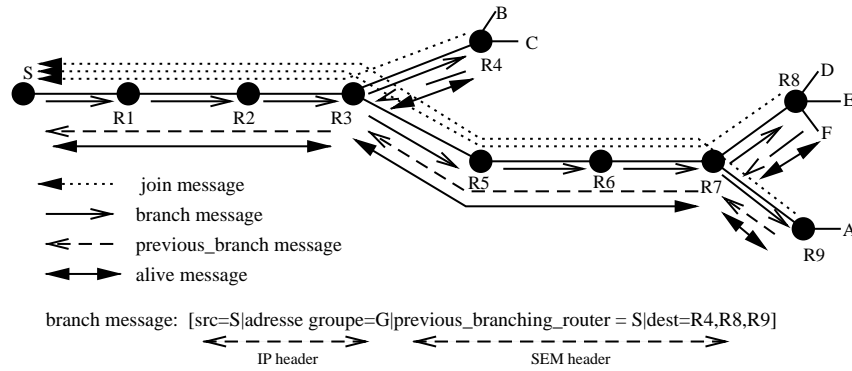

Fig. 5. SEM tree construction.

contains the previous branching router address and the list of all the destinations routers (cf. Fig. 5). The initial value of the previous branching router is the address of the source itself.

In our example, no routing state is created in R1 and R2 for the channel (S, G). A routing state is created in R3 (an entry is inserted in the routing table (TRM) of R3). This routing state contains: the source address S, the group address G, an empty list for the next branching routers and the value of the address S, indicating the source of the message, for the *previous_branching_router* field. The new *branch* messages sent by R3 contains: S, G, the appropriate list of destinations (a *branch* message contains R4 and the second *branch* message contains R8 and R9), and R3 in the *previous_branching_router* field. By applying the same process, no state will be created in R5 and in R6. At the end of this operation, the (S, G) entries in R3, R7 will contain, respectively, R3, (R4, R7) and (R8, R9) as next branching routers for the channel.

3.3. The structure of branch and previous_branch messages

A specific protocol number is associated to SEM control messages. The protocol type of the IP header is SEM_PROTO. The SEM control messages are unicast (*previous_branch* and *alive*) and multicast (*branch*). The SEM Header always starts with the four following bytes:

0										1										2										3									
0	1	2	3	4	5	6	7	8	9	0	1	2	3	4	5	6	7	8	9	0	1	2	3	4	5	6	7	8	9	0	1	2	3	4	5	6	7	8	9
+---+---+---+---+---+---+---+---+---+---+										+---+---+---+---+---+---+---+---+---+---+										+---+---+---+---+---+---+---+---+---+---+										+---+---+---+---+---+---+---+---+---+---+									
SEM Ver										Type										Reserved										Checksum									
+---+---+---+---+---+---+---+---+---+---+										+---+---+---+---+---+---+---+---+---+---+										+---+---+---+---+---+---+---+---+---+---+										+---+---+---+---+---+---+---+---+---+---+									

The version number (SEM Ver) is 1. The Checksum is calculated in a similar way to TCP. The different types of a SEM message are:

- 0 = branch
- 1 = previous_branch
- 2 = join
- 3 = leave

- 4 = alive
- 5 = data

The *branch* message is always placed in IP multicast packet. The IP Header of the datagram containing the *branch* message will carry the address of the source S and the address of the group G (as a destination). The SEM header contains the field *previous_branching_router* which represents the previous branching router address⁷ and the list L of all DR addresses which have sent a *join* message to the source for the channel (S, G) (cf. Appendix A.1). The *previous_branch* message is always placed in IP unicast packet. The IP header of the datagram containing the *previous_branch* message contains the router itself as source address and the previous branching router as a destination address. The SEM header of the *previous_branch* message contains the addresses of the source and the group (the channel (S, G)) (cf. Appendix A.2). The *alive* message is always placed in IP unicast packet. The IP header of the datagram containing the *alive* message sent by a router B towards p_B, the upstream previous branching router on the tree, will carry B as source address and p_B as destination address. The SEM header contains the two addresses S and G which represents the channel (S, G) (cf. Appendix A.5). A *join* message or a *leave* message is always placed in IP unicast packet. The IP Header of the datagram containing this message sent by a router R towards the source, will carry R as source address source and S as destination

address. The SEM header contains the two addresses S and G which represents the channel (S, G) (cf. Appendices A.3 and A.4).⁸ The data packets sent in SEM mode are IP unicast

⁷ In the initial message, the value of this field contains the address of the source.

⁸ Another way to implement these two messages is to use the same format of join/prune messages like those used in PIM-SM.

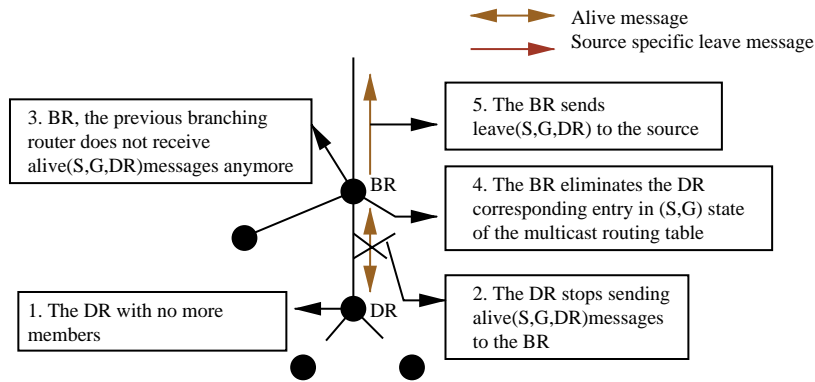

Fig. 6. The case when *DR* does not have members anymore.

packets. The IP header of the datagram containing the data in SEM mode contains the address of the source and the address of the next branching router. The SEM header contains only *G*, the group address (cf. Appendix A.6).

3.4. Data packet processing in SEM mode

When the source starts sending packets to a group, the state of the corresponding channel is examined.⁹ A packet is forwarded directly in mode SEM (unicast) to the next branching routers. When the subsequent branching routers receive the packet, the same operation is repeated. Thus, if the router receiving the packet is not the next branching router for that packet, it forwards the packet in unicast to the specific next branching router. When the packet arrives at the router in the destination field, it is replicated and sent to each next branching router. When the packet arrives to one *DR*, the packet destination field should be replaced with the *G* address to ensure that it will be delivered through multicast to all receivers in the subnet of that *DR*.

3.5. Maintenance of SEM tree

Alive messages are used between branching routers to maintain the SEM tree. When a *DR* discovers that there are no more receivers in its directly connected subnet for a particular channel (*S*, *G*), the *DR* ceases sending *alive(S, G)* messages towards the previous branching router. The previous branching router eliminates the corresponding state (it stops forwarding packets to the leaf router) and generates a source specific *leave* message (sent directly to the source). When receiving the *leave* message, the source eliminates the corresponding state and sends a new *branch* message to rebuild the tree (cf. Fig. 6).

Moreover, when one *DR* or a branching router breaks down, the previous router will not receive any more *alive* messages and thus eliminates the routing state. It sends also a *leave* message to the source which sends a new *branch* message to rebuild the tree.

A timer at the source is associated with the control state for each channel (*S*, *G*). A *branch* message is not sent directly after receiving a *join* message or a *leave* message. The arrival of a *join* or a *leave* arms the timer associated with the channel (*S*, *G*). The source waits until this timer expires to send a new *branch* message. During all this phase of tree construction, packets will be sent in GXcast mode.

Fig. 7 describes the behavior of the source when it receives a *join(S, G)* message or a *leave(S, G)* message according to the expiration of the timer associated with the channel (*S*, *G*).

4. Comparison between SEM and HBH

There are many similarities between SEM and HBH but also many differences in the forwarding scheme and the control plane. We briefly describe the tree management mechanisms for REUNITE and HBH and we compare them then to SEM.

4.1. REUNITE tree management mechanism

In REUNITE, *join* messages are generated periodically by each receiver and are sent in unicast towards the source of the group. *tree* messages are generated periodically by the source of the group and are sent¹⁰ towards all receivers present in the MFT table at the source. When a new receiver subscribes with the group, it sends a *join* message towards the source. If the *join* message is intercepted by a router having a non-empty MCT, this router becomes a branching router. The router eliminates then the control table MCT and creates a routing table MFT.

For better understanding the tree management mechanism of REUNITE, let us take the example of Fig. 8. Let us suppose the following unicast paths: $R_1 \rightarrow H_2 \rightarrow H_1 \rightarrow S$; $S \rightarrow H_1 \rightarrow H_3 \rightarrow R_1$; $R_2 \rightarrow H_3 \rightarrow H_1 \rightarrow S$; $S \rightarrow H_4 \rightarrow R_2$; $S \rightarrow H_1 \rightarrow H_3 \rightarrow R_3$ et $R_3 \rightarrow H_3 \rightarrow H_1 \rightarrow S$.

¹⁰ *tree* messages are unicast messages but we consider them as multicast messages since they generate other *tree* messages which will reach all the group receivers.

⁹ Data packet processing in GXcast mode will be studied in Section 4.5.

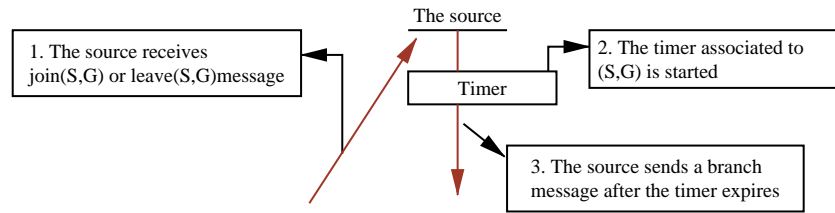

Fig. 7. The timer associated to a channel and the messages *join* and *leave*.

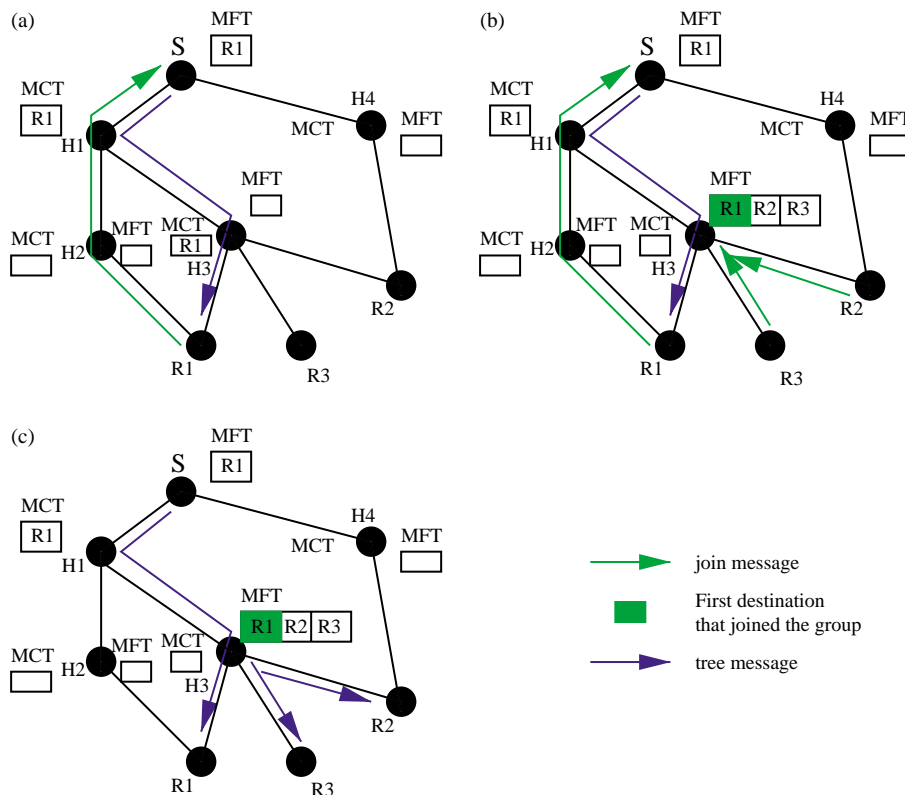

Fig. 8. REUNITE tree management mechanism.

Suppose that $R1$ subscribes first to the group, then $R2$ and finally $R3$. $R1$ subscribes to the group by sending a $join(S, G, R1)$ towards S . This message arrives at S which adds $R1$ to its MFT. S starts sending $tree(S, G, R1)$ on the tree. These messages create entries $(S, G, R1)$ in the MCT of $H1$ and $H3$. Data follows the same path towards $R1$. Then, when $R2$ subscribes by sending a $join(S, G, R2)$ towards S , this message is intercepted by $H3$ since this router already installed the state for this channel. $H3$ creates a MFT with $R1$ as a next router¹¹ to follow by the packets and adds $R2$ as a receiver. Also, $R3$ is added to the MFT as a receiver. When packets are received from S towards $R1$, two copies are created and sent to $R2$ and $R3$. Note that $R1$ and $R3$ receive the packets sent by S through the shortest path. It is not however the case for $R2$. When a REUNITE router

receives a packet, it extracts from this packet the source and destination addresses and the source port number and consults the table MFT. If the entry is not found, then a second consultation is done in the unicast routing table. Thus, when a unicast packet is received, two lookups are required. REUNITE does not propose any solution to this significant problem but it supposes that since the lookup of the MFT table is based on an exact correspondence of the address and not on a correspondence of the longest prefix, this double lookup is fast.

4.2. HBH tree management mechanism

HBH uses three types of messages to construct the multicast tree: *join*, *tree* and *fusion*. The *join* messages are periodically sent in unicast by the receivers towards the source, and are used to refresh the routing state (the entry in the MFT) in the router to which the receiver is connected.

¹¹ This is Called dst in [7].

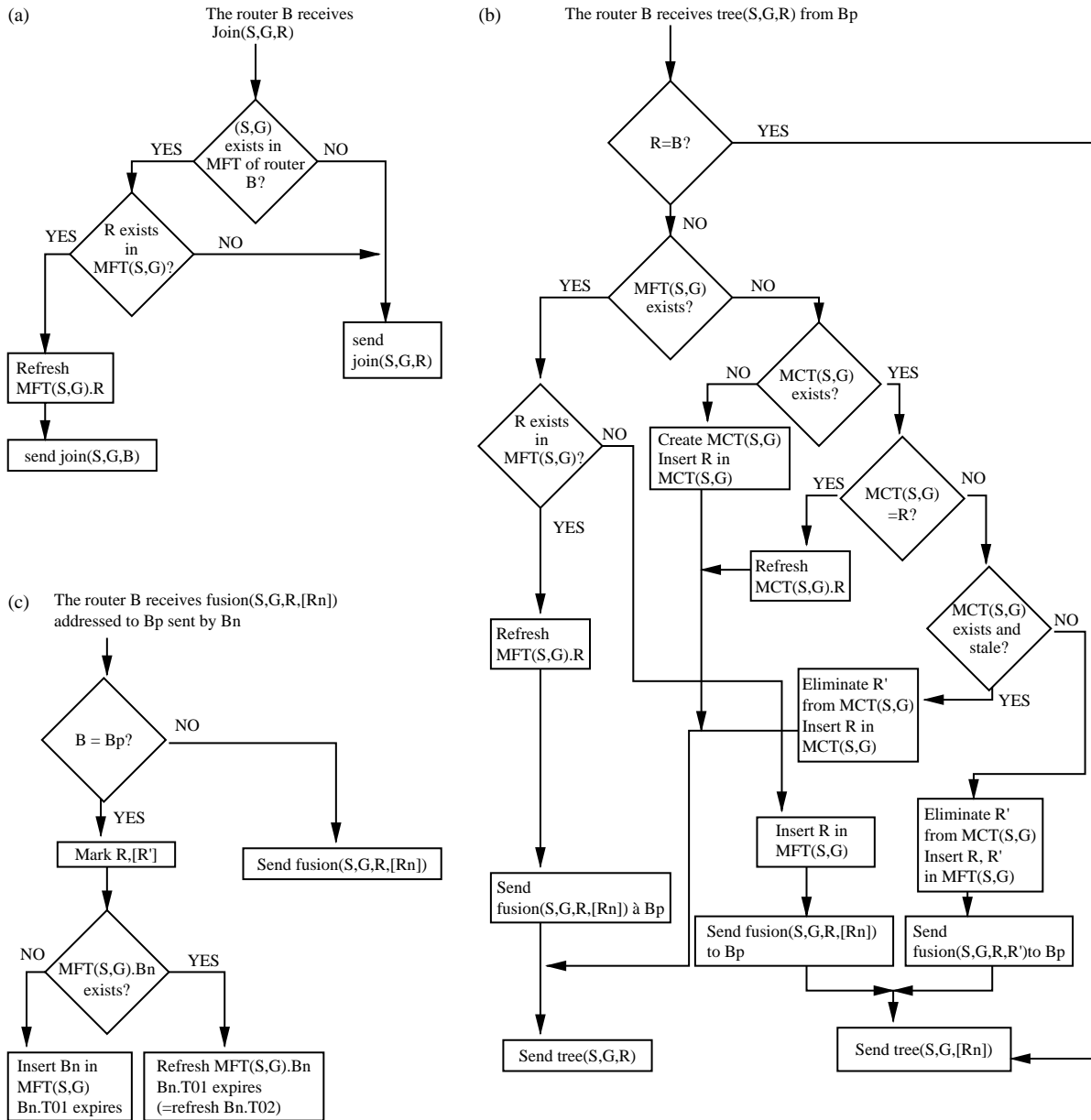

R' is the router address in MCT(S,G)
 [Rn] is the list of routers addresses in MFT(S,G)

Fig. 9. The processing of the different messages in HBH. (a) join message; (b) tree message; (c) fusion message.

The source sends periodically in multicast a *tree* message¹² for each channel (S, G) which is used to refresh the structure of the tree. *fusion* messages are sent in unicast by potential branching routers in order to construct the tree, using the *tree* messages received from the source. Fig. 9 shows the processing algorithms for the three type of messages used in HBH.

Each HBH router on the (S, G) tree has either an MCT if it is not a branching router or an MFT for (S, G) if it is. The MCT for a channel (S, G) can have only one entry, which are

associated two timers, *t1* and *t2*. When *t1* expires, the entry becomes *stale*.¹³ When *t2* expires, the entry (the MCT consequently) is destroyed. A node on the tree for a channel (S, G) but which is not a branching node will have an MCT for (S, G). The entry in the MFT can also be marked.¹⁴

Let us take the same example of the preceding paragraph. R1 subscribes to the channel (S, G) and S starts sending *tree(S, G, R1)* messages. These messages create an MCT for

¹² We study the transmission mode of this tree message later on.

¹³ *stale* entry is used for the routing of multicast packets on the tree, but does not generate any tree message downstream.

¹⁴ Marked entry will generate a tree message but not data packets.

(S, G) (that contains $R1$) in $H1$ and $H3$. When $R2$ starts sending $join(S, G, R2)$ while subscribing with the group, this message is not intercepted and reaches the source which starts sending $tree(S, G, R2)$ (the first $join$ sent by the receiver is never intercepted and always arrives at the source). The $tree(S, G, R2)$ messages sent by the source create a state for the channel (S, G) in the MCT of $H4$ (cf. Fig. 10b).

$R3$ sends a $join(S, G, R3)$ towards S which starts sending $tree(S, G, R3)$. As soon as $H1$ starts receiving two different $tree$ messages, it sends a $fusion(S, G, R1, R3)$ message towards the source. When receiving this $fusion$ message by S , it causes the addition of $H1$ in the table MFT of S , and the marking of $R1$ and $R3$. In the same way that $H1, H3$ receives $tree(S, G, R1)$ and $tree(S, G, R3)$ message $R3$ sends a $join(S, G, R3)$ towards S which starts sending $tree(S, G, R3)$. As soon as $H1$ starts receiving two different $tree$ messages, it sends a $fusion(S, G, R1, R3)$ message towards the source. When receiving this $fusion$ message by S , it causes the addition of $H1$ in the table MFT of S , and the marking of $R1$ and $R3$. In the same way that $H1, H3$ receives $tree(S, G, R1)$ and $tree(S, G, R3)$ messages and sends consequently a $fusion(S, G, R1, R3)$ message towards $H1$. When receiving the message $fusion(S, G, R1, R3)$, $H1$ adds $H3$ in its table MFT and mark the two entries $R1$ and $R3$. The MFT of $H3$

contains now $R1$ and $R3$. The subsequent $join(S, G, R1)$ will be intercepted by $H1$ (and will refresh the entry marked for $R1$ in the MFT of $H1$). The $join(S, G, R3)$ will refresh the entry $R3$ in the MFT of $H3$. The packets are addressed by S to $H1$ then to $H3$, which sends them to $R1$ and sends a copy to $R3$. As S will not receive anymore a $join$ resulting from $R1$ and $R3$, the marked entries of $R1, R3$ disappear at the expiration of the corresponding timers. The final structure is that of Fig. 10d.

4.3. SEM tree management mechanism

SEM uses three messages to construct the multicast tree: $join$, $branch$ and $previous_branch$. Moreover, $alive$ messages replace $join$ messages after sending of the first $join$ towards the source and they are periodically sent in unicast by the receivers towards the previous branching router on the tree. Thus, these $alive$ messages are used to refresh the routing state in the router to which the receiver is connected.

The source sends a $branch$ message of type GXcast (cf. Section 4.4) to discover the branching routers on the tree. $previous_branch$ messages are sent in unicast by potential branching routers in order to build the structure of

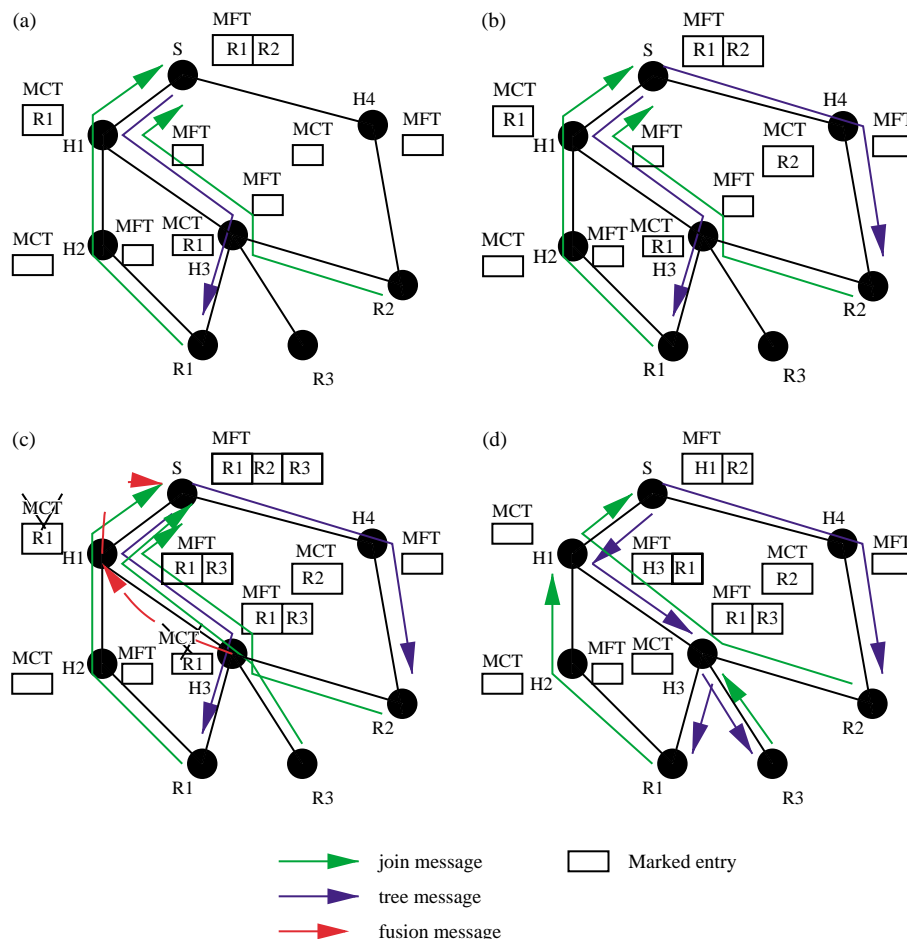

Fig. 10. HBH tree management mechanism.

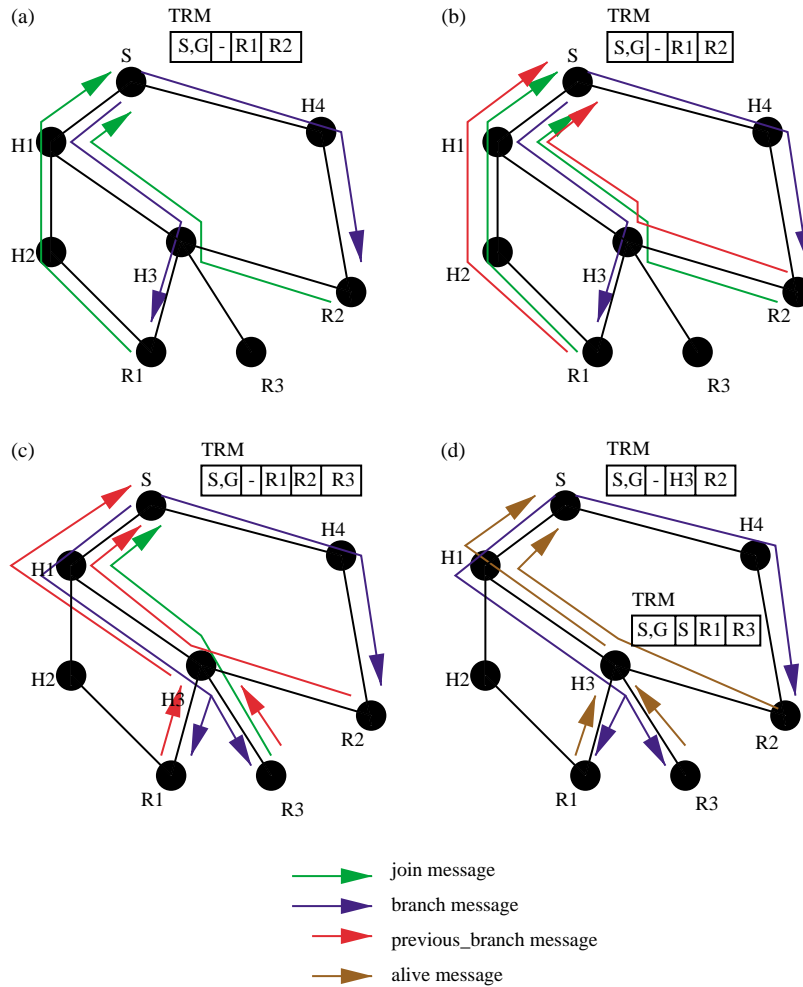

Fig. 11. SEM tree management mechanism.

distribution of the tree, using the messages *branch* received from the source.

A receiver sends the first *join* message in unicast towards the source. The source sends a message *branch* of GXcast type on each channel (S, G) . Contrary to REUNITE and HBH, SEM eliminates any presence of a routing state (equivalent to MFT) or of a control state (equivalent to MCT) in the intermediate routers on the multicast tree who are not branching routers. A SEM branching router in the distribution tree of (S, G) has only one routing state for each channel (S, G) ($TRM(S, G)$). SEM simplifies the routing algorithm by also eliminating the presence of marked entries or *stale* entries. To each entry in the routing state is associated a timer, $t1$. When $t1$ expires, the entry is destroyed.

Let us consider the example of Fig. 11. $R1$ subscribes to the channel (S, G) and S starts sending $branch(S, G, p_B = S, R1)$ messages. $R1$ sends then a $previous_branch(R1, p_B = S, S, G)$ message. These messages create a routing state for (S, G) (contains $R1$) in S . When $R2$ sends a $join(S, G, R2)$ message to subscribe the group, this message is not

intercepted and reach the source¹⁵ who starts sending a $branch(S, G, p_B = S, R1, R2)$ message. Thereafter, *alive* messages replace *join* messages to maintain the tree.

The $branch(S, G, p_B = S, R1, R2)$ message sent by the source generates $previous_branch(R2, p_B = S, S, G)$ message sent by $R2$ towards S and thus creating the state for the channel (S, G) in S . This state contains $R1, R2$ (since the two paths from S to these receivers are different) (cf. Fig. 11b). When $R3$ sends a $join(S, G, R3)$ message towards S , S starts sending $branch(S, G, p_B = S, R1, R2, R3)$ messages. The GXcast mechanism of the *branch* message discovers the branching routers for the channel (S, G) (S and $H3$ are two branching routers on the tree). S intercepts the $branch(S, G, p_B = S, R1, R2, R3)$ message and generates two messages: $branch(S, G, p_B = S, R1, R3)$ and $branch(S, G, p_B = S, R2)$, the first on the interface connecting S to $H1$ and the second on the interface connecting S to $H4$. In the same way, $H3$ generates also two *branch* messages: $branch(S, G, p_B = H3, R1)$ and $branch(S, G, p_B = H3, R3)$. The *previous_branch*

¹⁵ The first join is not never intercepted and always arrives at the source.

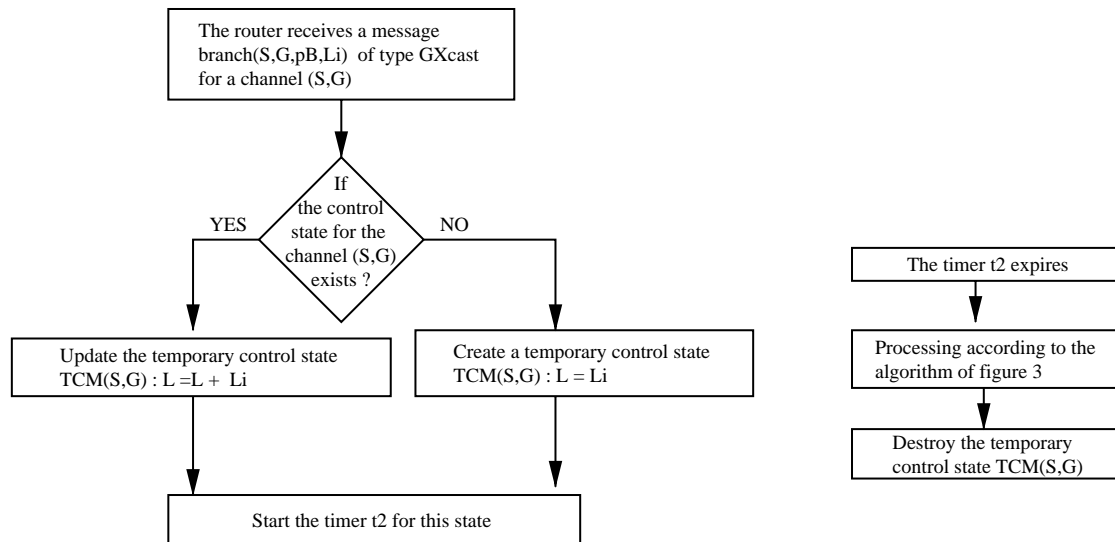

Fig. 12. The processing of a *branch* message of type GXcast in a SEM router.

messages generated by $R1$, $R2$ and $R3$ as response to the *branch* messages create finally routing states in S (It contains $H3$ ¹⁶ and $R2$ as entries) and in $H3$ (It contains $R1$ and $R3$ as entries). The data sent by S to $H3$ are sent to $R1$ and $R3$. Moreover, the receivers periodically send *alive* messages towards the previous branching routers to maintain the tree. The *alive*($S,G,R1$) and *alive*($S,G,R3$) messages sent by $R1$ and $R3$ are intercepted by $H3$ which sends an *alive*($S,G,H3$) message towards the source S . The final structure is that of Fig. 11d.

4.4. The *branch* message of type GXcast

At most 135 *IP* addresses can be encoded in an Xcast packet, and it is the same for a *branch* message¹⁷ [6]. A *branch* message for a group having more than 135 *DR* can be divided into several *branch* messages of type GXcast. At the arrival of a *branch* message at a router, a temporary control state $TCM(S,G)$ is created in the router containing the list (L_i) of addresses of the *DR* in the SEM header of the *branch* message ($TCM(S,G):L=L_i$) and a timer $t2$ is associated to this state. At the arrival of the next *branch* for the same channel (S,G) and if the timer did not expired, the new list of *DR* addresses in the SEM header of the *branch* message is added to the state corresponding to the channel (S,G) ($TCM(S,G) : L = L + L_i$) and the timer is started again. This operation is repeated for each *branch* message for all the sublists L_i for the main list L . If the timer $t2$ expires, the router process the list L in the control state, classifies the destinations in sublists L_j according to their next router, generates a *branch* message with the appropriate SEM header and sends it towards each next router. Fig. 12 shows the processing of a *branch* message of type

GXcast in a SEM router. When $t2$ expires, the temporary control state is destroyed.¹⁸

4.5. The transmission of *branch* messages of type GXcast and the rapidity of tree construction

It is clear that the construction time of the tree by the three protocols REUNITE, HBH and SEM is higher than the construction time of the tree by a conventional multicast routing protocol (for example, PIM-SM). This is due to the fact that the construction of the tree does not depend with these three protocols only of the conventional *join* messages which build the tree in an effective and fast way. Indeed, the first *join* messages of HBH and SEM must always reach the source. The construction of the tree in REUNITE is carried out by using *join* messages and *tree* messages together. Moreover, to these messages, *fusion* messages are added in the case of HBH. These messages are identical to the messages used in SEM.

SEM eliminates any presence of routing states or control states in the intermediate routers who are not branching routers for the tree. This brings that the tree maintenance at the departure of a member is easier in HBH.

SEM uses a very effective mechanism to avoid this disadvantage. Indeed, during the tree construction, the SEM protocol uses the transmission in GXcast mode to deliver the data packets. Once the tree is built, the transmission in SEM mode is again used. If the groups are very dynamic, one falls into the case of pure GXcast protocol. If the groups are fairly dynamic or quasi-stable, the tree built by SEM is quasi-stable too. At the source of a SEM tree, the algorithm of Fig. 13 is used.

¹⁶ As a next branching router.

¹⁷ MTU=576 bytes, 12 bytes for SEM header (cf. Appendix A.1).

¹⁸ Note that the control state $TMC(S,G)$ for a channel (S,G) at the source is never destroyed. The source will always need the list of the receivers.

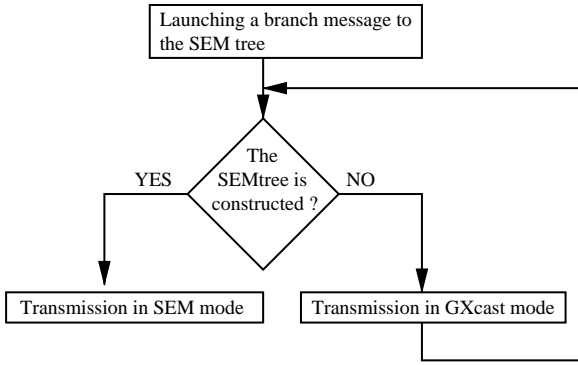

Fig. 13. The packet forwarding algorithm in GXcast mode during the SEM tree construction.

4.6. Comparison between SEM and HBH

4.6.1. Table size reduction

According to HBH specifications, MFT entries exist in branching routers and MCT entries exist in all other intermediate routers on the tree. HBH protocol tried to eliminate routing states from nonbranching routers while conserving control states in these routers. But as we already saw in Fig. 10d with the HBH’s tree construction mechanism (see also Fig. 5 in [8]), nonbranching routers may still have multicast routing state. Unlike HBH, there is no need for MFT neither for MCT tables in nonbranching routers.

Let us take the example of Fig. 14. Let us suppose the following unicast routes: $R1 \rightarrow H2 \rightarrow H1 \rightarrow H0 \rightarrow S$;

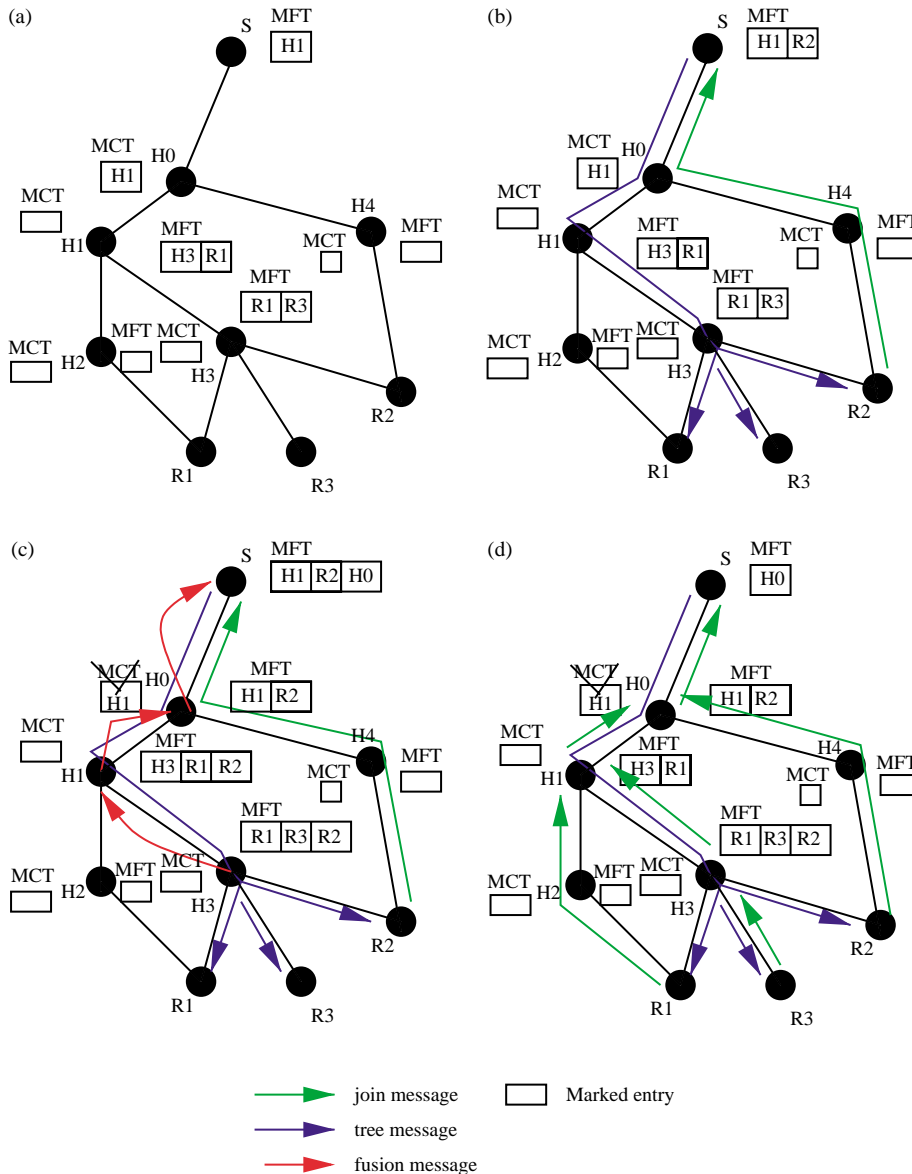

Fig. 14. Comparison of tree states reduction between SEM and HBH.

$S \rightarrow H0 \rightarrow H1 \rightarrow H3 \rightarrow R1$; $R2 \rightarrow H4 \rightarrow H0 \rightarrow S$; $S \rightarrow H0 \rightarrow H1 \rightarrow H3 \rightarrow R2$; $R3 \rightarrow H3 \rightarrow H1 \rightarrow H0 \rightarrow S$; $S \rightarrow H0 \rightarrow H1 \rightarrow H3 \rightarrow R3$. This network is asymmetrical since some routes are asymmetric.

Let us apply the HBH protocol mechanism. $R1$ subscribes with the channel (S,G) and S starts sending $tree(S,G,R1)$ messages. These messages create a MCT for (S,G) (it contains $R1$) in $H0$, $H1$ and $H3$. $R3$ sends a $join(S,G,R3)$ towards S which starts sending $tree(S,G,R3)$. Following the same reasoning as that of Section 4.2, the structure of the tree at the end of this phase is that of Fig. 14a.

Let us suppose now that $R2$ starts to send $join(S, G, R2)$ in order to subscribe to the group, these messages are not intercepted and reach the source which starts to send $tree(S, G, R2)$ (cf. Fig. 14b). As soon as $H0$ starts to receive two different $tree$ messages ($tree(S, G, H1)$ and $tree(S, G, R2)$), it destroys the MCT and creates an entry for (S, G) in its MFT, that contain $H1$ and $R2$, and it sends a $fusion(S, G, H1, R2)$ message towards the source. The reception of the $fusion$ by S involves the addition of $H0$ in table MFT of S , and the marking of $H1$ and $R2$. As same as in $H0$, $H1$ receives the message $tree(S, G, R2)$ and sends consequently a $fusion(S, G, H3, R1, R2)$ towards $H0$. The reception of the $fusion$ by $H0$ involves the addition of $H1$ in its table MFT, and the marking of $R2$. $H3$ receives $tree(S, G, R2)$ messages and sends consequently a $fusion(S, G, R1, R3, R2)$ towards $H1$. The reception of the $fusion$ by $H1$ involves the refreshing of $H3$ in table MFT, and the marking of $R2$ (cf. Fig. 14c). The final structure of the tree is that of Fig. 14d.

We deduce that if the network is asymmetrical (which is the case in Internet), the reduction of routing states with HBH is not sufficient. Note that when the number of groups increases in the network, the number of routing states grows too. In our example, if $R1$, $R2$ and $R3$ belong to n different multicast groups, we will have n routing states in each router on the multicast tree.

4.6.2. Control messages overhead

In order to build and maintain the HBH multicast tree, a $tree$ message is sent. The mode of diffusion of the message is not detailed in HBH proposal. We consider three modes of diffusion: multicast, unicast and recursive unicast.

HBH does not use the conventional multicast routing. No conventional multicast routing state exists in the intermediate routers and thus a $tree$ message cannot be sent in multicast mode. Moreover, one $tree$ message must follow the shortest path unicast between the source and the receiver and not a RPF (Reverse Path Forwarding) path between the source and the receiver like that borrowed by the $join$ message.

A $tree$ message can be sent in recursive unicast mode if the tree is already built. Thus, the message reaches all the receivers, but its IP destination address is modified according to recursive unicast when progressing on the tree. The problem arises during the tree construction. Indeed, the first $join$ message is sent directly to the source

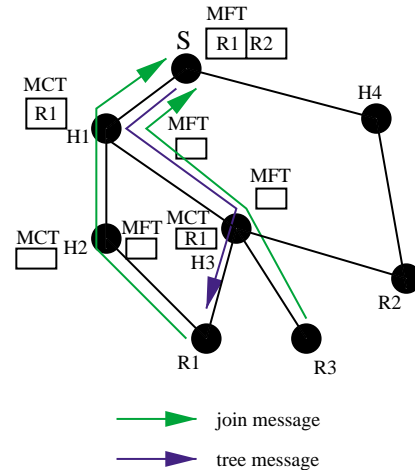

Fig. 15. The $tree$ message in recursive unicast mode.

and does not keep any information in the intermediate routers concerning the receiver who sent the $join$ message. Thus there is no information concerning the receivers in the intermediate routers that can be used by the $tree$ message for the routing in recursive unicast mode.

Let us take the example of Fig. 15. $R1$ subscribes to the channel (S, G) and S starts sending $tree(S, G, R1)$ messages. These messages create a MCT for (S, G) (it contains $R1$) in $H1$ and $H3$. $R3$ sends a $join(S, G, R3)$ towards S which starts to send $tree(S, G, R3)$. There is no means for S to send $tree$ messages in recursive unicast. Indeed, in the case of the recursive unicast, S will send a $tree$ message to $R1$ and then in $H3$ there will be a duplication of the $tree$ message: the initial message for $R1$ and a copy for $R3$. But since there is no state in $H3$ during the construction of the tree, the recursive unicast cannot be used in this case.

Thus it seems to us that the $tree$ message described in HBH cannot be else than unicast and a $tree$ message is sent for each receiver. Once the tree is stable, a $tree$ message in recursive unicast mode can be sent.¹⁹

It remains only the unicast mode: for each receiver who subscribes with the channel (S, G) , a $tree$ message is sent from the source towards this receiver. This seems to us the best adapted with the description made in [8] (cf. Fig. 9). The number of $tree$ messages sent periodically in HBH is thus proportional to the number of receivers.

Consequently, by sending the $tree$ message in order to build the HBH tree, this $tree$ message passing through a router always generates new $tree$ messages for all the entries of the table MFT. Fig. 16 shows a tree HBH in the phase of construction. The two routers $R1, R2$ send their $join$ messages to the source. In response to the $join$ message of $R1$, the source sends a $tree$ message towards $R1$ which creates a table MCT in each router between S and $R1$. Following

¹⁹ In fact, there is no big difference between a recursive unicast message and unicast when the tree is stable, since the destination of the $tree$ message is the next branching router on the multicast tree already built.

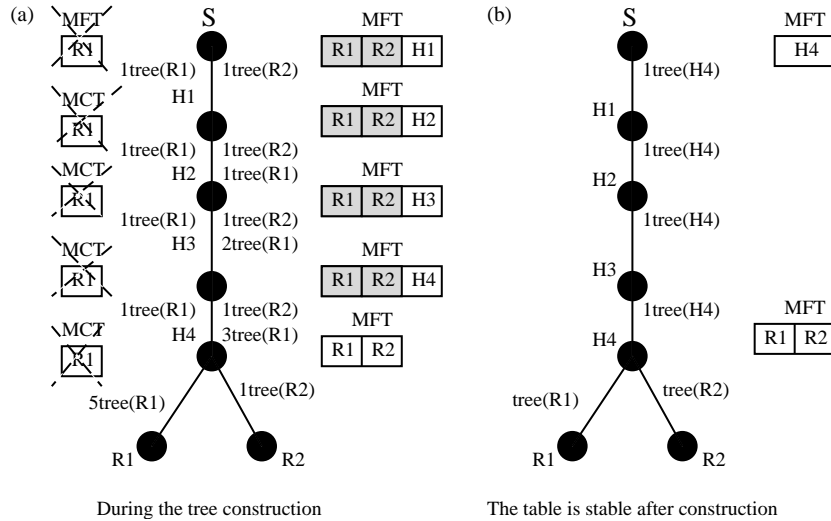

Fig. 16. The *tree* message in unicast mode.

the message *join* of *R2*, the source sends a *tree* message towards *R2*. This *tree* message destroys the table MCT in the next router (*H1*) and creates a table MFT in its place with *R1* and *R2* as entries in this table. A *tree* message is generated then for each entry in the new table MFT (*R1* and *R2*). This operation is repeated for each router between the source and the destinations. We deduce that during the phase of construction of the tree and before the marked entries expired, 5 *tree* messages are generated for the router *R1* and only one message *tree* is generated for the router *R2*. Each new *join* message for a new destination has the same effect on the tree until all the marked entries expire. Once the tree is built, the marked entries will expire and HBH solves the problem automatically since the entries of next branching routers are always *stale* (entries that allow the data packets routing but do not generate any *tree* message). This is only true if the *tree* messages are not sent immediately after the periodic *join* messages which refresh the *stale* entries. If not, this problem of flooding persists. HBH can limit the effect of this problem by using a timer like that used in Section 4.4 for the *branch* messages of type GXcast.

To build the multicast tree, we consider in SEM that the use of a *branch* message of type GXcast (which has a similar role of HBH *tree* messages) is the best adapted for the multicast tree construction.

We conclude that the tree construction is simpler in SEM than in HBH. The presence of MCT and MFT in the routers, the processing of messages *tree* and *fusion* and the large number of these messages during the tree construction phase add some complexity to the protocol HBH compared to SEM.

5. Analytical evaluation

We have evaluated our approach in terms of scalability (forwarding table size and control messages overhead) and efficiency (tree cost, delay and data processing).

5.1. Forwarding table size

We consider the parameter α of a distribution tree *T* to be the average number of multicast forwarding table entries per router for a tree:

$$\alpha(T) = \frac{Ne}{NT} \tag{1}$$

where *Ne* is the sum of the total number of multicast forwarding table entries, i.e., the total number of (S,G) entries, on all the routers for distribution tree *T*, and *NT* is the number of routers on the tree. In a source specific distribution tree, every router contains one (S, G) forwarding table entry for the distribution tree, in which case $Ne = NT$ and the value of the α parameter reaches its maximum 1.0 for source specific trees. The minimum α value for any particular tree is defined by the following equation:

$$\alpha_{\min}(T) = \frac{Nb + Nl + Ns}{NT} \tag{2}$$

where *Nb* is the number of branching routers on tree *T*, *Nl* is the number of leaf node routers on the tree, *Ns* is the number of sources of the tree which always 1, and *NT* is the total number of routers on tree *T*. The α parameter of a tree reaches its minimum when all uni-multicast routers on the tree are bypassed by dynamic tunnels.

We observed that in a multicast topology (constructed tree) resulting from a traceroute experiments from the IRISA (university of Rennes 1) to 5 sites in France, there are only 4 branching routers out of 30 routers. We deduced that the α parameter value is smaller than 34% when using tunnels between branching routers which implies that we can achieve over 66% reductions in multicast forwarding table size using our approach.

5.2. Data processing and delay

The source in Xcast encodes the list of destinations in the Xcast header, and then sends the packet to a router. Each router along the path parses the header, partitions the destinations based on each destination's next hop, and forwards a packet with an appropriate Xcast header to each of the next hops.

The Xcast packet header processing time in a router ($Xhdrt$) is approximately proportional to the number of entries in the list of destinations present in the Xcast packet. It could be defined by the following equation:

$$Xhdrt = Nl \times Uhdrt \quad (3)$$

where Nl is the number of leaf node routers on the tree (number of entries in the list of destinations) and $Uhdrt$ is the header processing time needed for a unicast packet.

Using the SEM protocol, only *branch* messages need extra header processing time. Comparing to Xcast, the packet header processing (and thus delay) in SEM is minimized.

5.3. Tree cost and control overhead analysis

Our approach has an advantage over conventional multicast protocols like PIM-SM and CBT since we do not force multicast packets to be sent all the way to the Rendez-Vous point and next to receivers. Packets follow only shortest paths between source and receivers. Thus, SEM presents better support for networks with asymmetric routes. Besides there is no switching between shared tree and source specific tree. During the tree construction in HBH, as explained in [8], there are a huge number of periodic *join* messages, *tree* messages and *fusion* messages especially when considering networks with asymmetric routes.

Otherwise, the control overhead of SEM can be measured using the total number of control packets sent per link or the total percentage of bandwidth spent on control traffic. In both PIM-SM and SEM, each distribution tree needs to be refreshed periodically. SEM uses *branch* messages, *previous_branch* messages and *alive* messages to ensure the tree maintenance. The first join message reaches always the source, while in PIM-SM it is intercepted by the nearest router that already joined the channel. The number of control packets needed to refresh the states in PIM-SM and SEM would have been roughly the same, if there are no dynamic *join* and *leave*, since *alive* messages between two branching routers have the same impact as periodic *join* messages between routers in PIM-SM.

6. Simulation analysis

We simulate SEM in NS (Network Simulator) [13] to validate the basic protocol behavior and its efficiency, especially its effectiveness in table size reduction in routers and in tree construction. The performance of SEM is

Table 1
The simulation parameters for the SEM protocol

N	100	Number of nodes in the network
P	10, 20, 30, 40, 50, 60	Percentage of sources among network nodes (number of trees)
N_{DR}	3, 6, 9, 12, 15, 18	Number of DR destinations for every source

compared to PIM, Xcast and HBH. PIM in our simulations refers to the simulation with NS of PIM-SM that constructs only source specific trees. In addition to SEM, we have simulated Xcast according to [5] and some of HBH mechanisms according to [8].

We present two simulation models generated using the GT-ITM scenario generator [14]: both models with flat graph of 100 nodes and bidirectional 20 Mbps bandwidth links. The topology of the first model (used as a dense mode network) is based on the first algorithm of Waxman [15] with 0.3 as the node degree distribution. The topology of the second model (used as a sparse mode network) is based on the pure random algorithm [15] and is divided into five domains. Four domains contain destinations and sources only, while the fifth domain is considered as the core domain. P (percentage of sources among the network nodes) and N_{DR} (the number of *DR* destinations for each source) are randomly deployed in the network.²⁰ The destinations join randomly the tree and there is no leave messages²¹. Table 1 summarizes the parameters used in the simulation.

6.1. Multicast routing tables size reduction

The routing tables size in all routes of the network for the first model of topology (dense mode and Waxman algorithm) is shown in Fig. 17 and that of the second model of topology (sparse mode and pure random algorithm) in Fig. 18. The horizontal axis is the percentage of active sources (among nodes) in the network, and the vertical axis is the total size of the multicast routing tables in the network. The polylines labeled PIM- x and SEM- x show the total size of routing tables PIM and Sem, respectively when the number of destinations by groups is x .

The multicast routing table size increases with the number of active groups and the number destinations, as discussed in Section 5.1. We deduce from Figs. 17 and 18 that the reduction of the number of routing states in SEM is roughly 40% for the dense mode and 80% for the sparse mode, respectively, in comparison with PIM. This is an expected result since in a dense network the number of branching routers is higher than that in a sparse network. We conclude that our protocol is more suitable for sparse mode networks.

²⁰ The number of receivers in the *DR* sub-networks can be much higher.

²¹ Our goal is to obtain a maximum number of routing states in routers to show the reduction obtained with SEM in comparison with PIM.

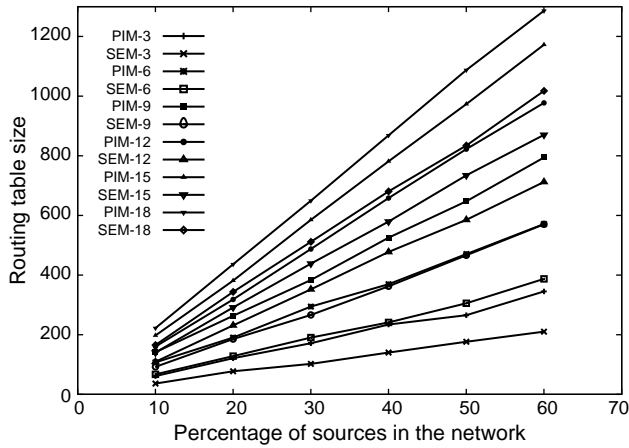

Fig. 17. Global routing tables size per group number in the network—dense mode and Waxman algorithm.

6.2. Table size reduction compared to HBH

We presented in Section 4.6 that SEM reduces better than HBH the number of routing states in an asymmetrical network. For simulations we used the topology suggested for HBH in [8]. This topology (cf. Fig. 19) is a typical ISP wide-area network (MCI) [16].

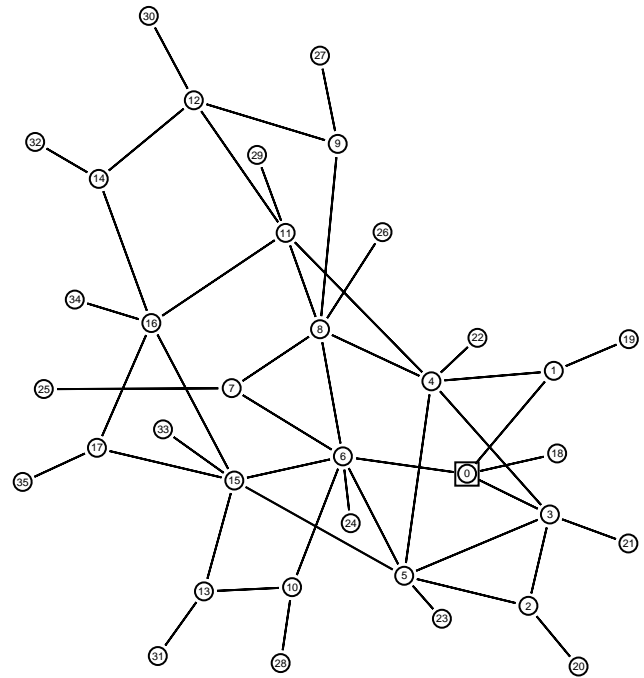

Fig. 19. The MCI topology.

Only one receiver is connected to each topology node. The presence of one or more receivers attached to the same node does not change the multicast tree cost. Nodes from 0 to 17 are routers (core network) while nodes from 18 to 35 are potential members of the multicast channel. We associate to the link $(n1, n2)$ which connects the nodes $n1$ and $n2$ two costs, $n1-n2$ and $n2-n1$ randomly chosen in the interval $[1, 10]$. We consider multicast channels of 1 to N receivers. The node 18 is fixed as the source. A variable number of receivers is randomly selected among the nodes 19–35. For each number of receivers, we realized, as in HBH, 500 simulations by algorithm.

Fig. 20 presents the average number of routing states for a channel in the network for SEM and HBH while Fig. 21 presents the cost overhead of the protocol HBH compared to the protocol SEM in term of this average number of routing states²². We notice (HBH % SEM) that SEM reduces at least 34% the average number of routing states. This reduction varies according to the number of receivers and can reach approximate 1y100%²³ for the channels having 2 receivers.

Table 2 shows the total number of entries in the routing tables for all the intermediate routers between the source and the receivers in the network. We consider 4000 channels in the network and we compare SEM to HBH. We notice that SEM has smaller number of entries in routing tables compared to HBH. This reduction in the total number of

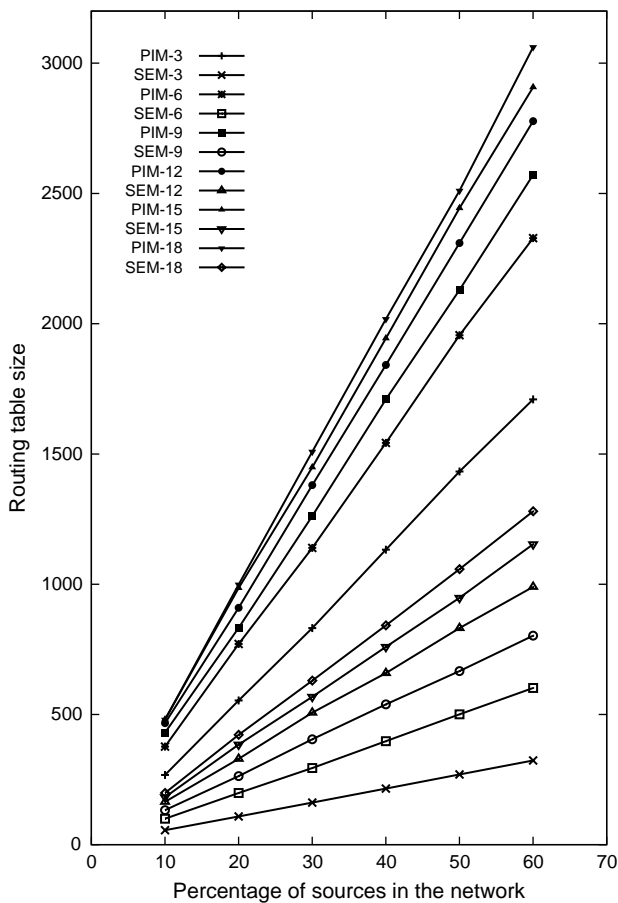

Fig. 18. Global routing tables size per group number in the network—sparse mode and pure random algorithm.

²² We considered only the routing states present in the intermediate nodes of the trees (essentially core nodes: neither source, nor destination).

²³ We already saw that there is 0 reduction of routing states in HBH compared to a multicast routing protocol for a channel like the one of the network presented in Fig. 14.

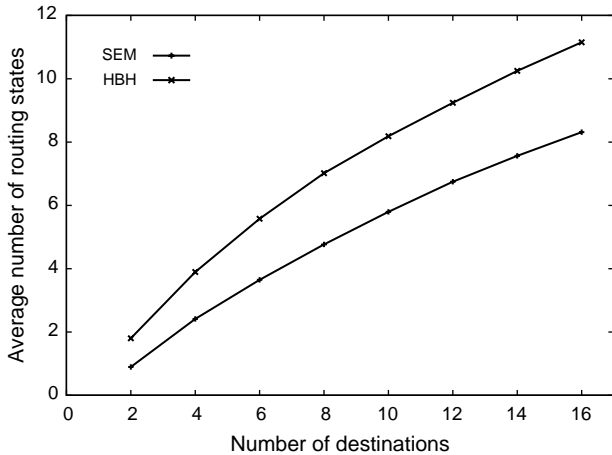

Fig. 20. The average number of routing states for SEM and HBH.

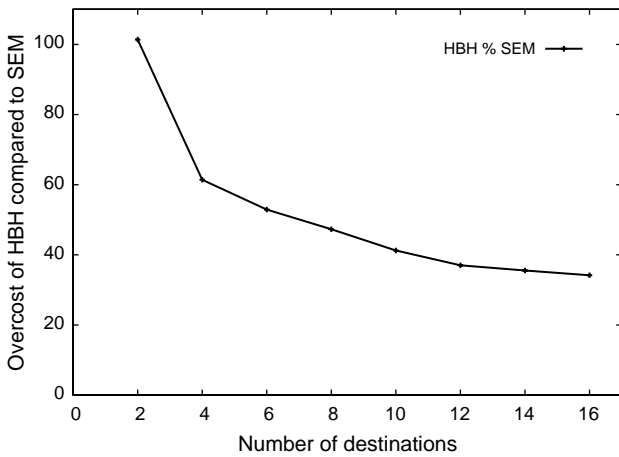

Fig. 21. HBH overhead compared SEM in term of average number of routing states for a channel.

entries in the routing tables becomes increasingly significant if the number of active groups in the network increases.

6.3. The tree cost and control messages overhead

SEM packets follow the shortest paths tree between the source and the destinations. This represents an advantage to SEM over conventional multicast routing protocols as PIM-SM (with a shared tree and a rendez-vous point) and CBT which send the multicast packets towards a rendez-vous point which in its turn return them to the destinations. This represents also an advantage to SEM over protocols like

Table 2
The global entry reduction in SEM routing tables compared to HBH in the network

Protocol	The total number of entries in the routing tables for all branching routers in the network for 4000 channels
SEM	20,054
HBH	28,529
Cost overhead	8475

Table 3
Control messages sent by the three protocols PIM, SEM and HBH

Protocol	Similar messages	Additional messages compared PIM
PIM	1 <i>join multicast</i> message 1 periodic <i>join</i> message	
SEM	1 <i>previous_branch</i> message	1 <i>join</i> message towards the source
HBH	1 periodic <i>alive</i> message	1 <i>branch</i> message
	1 periodic <i>join</i> message	1 <i>join</i> message towards the source
	1 <i>fusion</i> message	1 <i>tree</i> message towards all destinations 1 periodic <i>tree</i> message

PIM-SSM (With a source based tree) which use the reverse shortest path tree from receivers to the source. Thus the cost of the data transmission through the multicast tree build by SEM is lower than through that build by a conventional multicast routing protocol.

In HBH, the periodic *join* messages, the *tree* messages and the *fusion* messages generated during the tree construction phase cause a significant cost overhead. The cost overhead for protocol SEM can be measured by using the total number of control packets sent over links or the percentage of the band-width used by these control messages. Let us note that SEM uses *branch* messages, *previous_branch* messages to build the tree and periodic *alive* messages to ensure the tree maintenance.

In SEM, the first *join* message reaches the source. Between two branching routers there are periodic *alive* messages. In PIM, there are also periodic *join* messages between two routers on the multicast tree. If the same refreshing timer is chosen, the number of control packets is almost the same in PIM and SEM, if there are no changes in members of the multicast group (no new *join* or *leave* message)

Table 3 recapitulates the control messages sent by the three protocols: PIM, HBH and SEM.²⁴ The cost overhead in SEM compared to PIM results from the *join* messages sent directly to the source when a new receiver join the channel and from *branch* messages sent to build the tree. In the case of the fairly static groups the cost overhead due to these messages is not significant. On the other hand, with protocol HBH the number of control packets grows with time since the *tree* messages of HBH are sent periodically towards all the receivers of the group.

Fig. 22 presents the total number of control packets *branch* and *tree* for SEM and HBH²⁵ for the MCI topology represented in Fig. 3. The marked polylines *tree-src*, *branch-src* show the number of *tree* and *branch* messages generated by the source while the marked polylines

²⁴ To simply, we suppose that in this topology the network links are symmetrical.

²⁵ We consider that the trees are stable and we do not take account of the duplication of the tree messages presented in Section 4.6. Moreover, we do not consider the periodic tree messages of HBH.

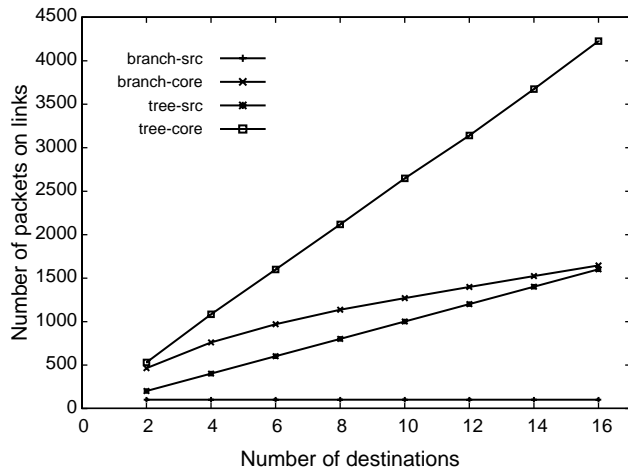

Fig. 22. Control packets overhead in HBH compared to SEM.

tree-core, *branch-core* show the number of *tree* and *branch* messages which crosses the core network of this topology. We deduce from Fig. 22 that the number of control messages for the tree maintenance in HBH is much higher than the number in SEM, which represents an advantage for SEM compared to HBH.

6.4. The comparison between the protocol SEM and the protocol GXcast

During the SEM tree construction, SEM transmit packets in GXcast mode. Once the tree is built, the mechanisms of protocol SEM are again used. If the groups are very dynamic, we fall in the case of the GXcast protocol. If the groups are fairly dynamic the tree built by SEM is quasi-stable too.

We made a comparison between several alternatives of SEM and the GXcast protocol. Indeed, we varied the utilization ratio of the GXcast protocol within protocol SEM. If the tree is not stable (very dynamic groups) the volume transmitted in the network approaches the volume transmitted by the GXcast protocol. If the tree is stable (static groups) the volume of data approaches a conventional multicast routing protocol. It should be noted that the cost overhead of the GXcast protocol comes from the packets size.

We take the Internet2 topology of the Abilene network²⁶ and we choose the following values for our parameters: 90, 140 and 190 receivers in a group.²⁷ Thus, graphs in Fig. 23 shows the quantity of transmitted data on all the links of the core network. The horizontal axis shows the quantity of transmitted data and the vertical axis shows the number of receivers (n takes the three following values: 90, 140 and 190) for a group. Polylines marked $P-x$ show the values obtained by transmitting $x\%$ of the traffic in SEM mode

and $(100-x)\%$ of the traffic in GXcast mode. According to the figures, we deduce that using GXcast during the phase of tree construction does not introduce a significant cost overhead compared to SEM if the percentage of using the GXcast mode is weak ($P=100$ and $P=95$, for example). This cost overhead becomes significant if the percentage of using the GXcast mode is high ($P=40$ and $P=0$). This is a normal and expected result due to the nature of the GXcast protocol. On the other hand, the use of the GXcast mode is an advantage for protocol SEM enabling him to reduce the latency problem (the non-reception of data packets by receivers during the phase of tree construction). This problem is crucial in the case of the dynamic groups.

6.5. Processing time and delay

The processing time of the GXcast header in each router grows with the size of the multicast group. In SEM, only the *branch* messages needs an additional processing which depends on the size of the multicast group. In comparison with GXcast, the total processing time of the packets and thereafter the delay are reduced at least in SEM. SEM allows a greater number of members and consume less resources than GXcast.

7. Conclusion and future works

In this paper, we proposed a new approach, Simple Explicit Multicast (SEM), which uses an efficient method to construct multicast trees and deliver multicast packets. In order to construct a multicast tree, the source encodes the list of destination addresses in a *branch* message. This message discovers branching routers in the multicast tree and creates entries (multicast routing states) in these routers for the multicast channel. For multicast packets delivery, it uses recursive unicast trees where packets travel from a branching router to another following the tree constructed by the *branch* message. SEM uses the source specific channel address allocation and implements data distribution using unicast trees. The application areas for SEM includes conferencing, multi-player games and collaborative working.

SEM, compared to Xcast, has control overheads, but the cost of packet header processing time is minimized. SEM presents some advantages over HBH protocol especially during the tree construction and in terms of multicast table size reduction in nonbranching routers. We confirmed through simulations that SEM can significantly reduce the number of multicast routing states and presents many advantages over other multicast protocols.

Our future work will focus on studying the latency problem in the case of very dynamic groups. We will study also extending our technique for many-to-many multicast, the possibility of including QoS parameters inside SEM tree construction and using SEM to construct trees with multicast mobile nodes.

²⁶ abilene.internet2.edu

²⁷ All the values of the simulation scenario parameters have been choosed from a real network game packet distribution [17,18].

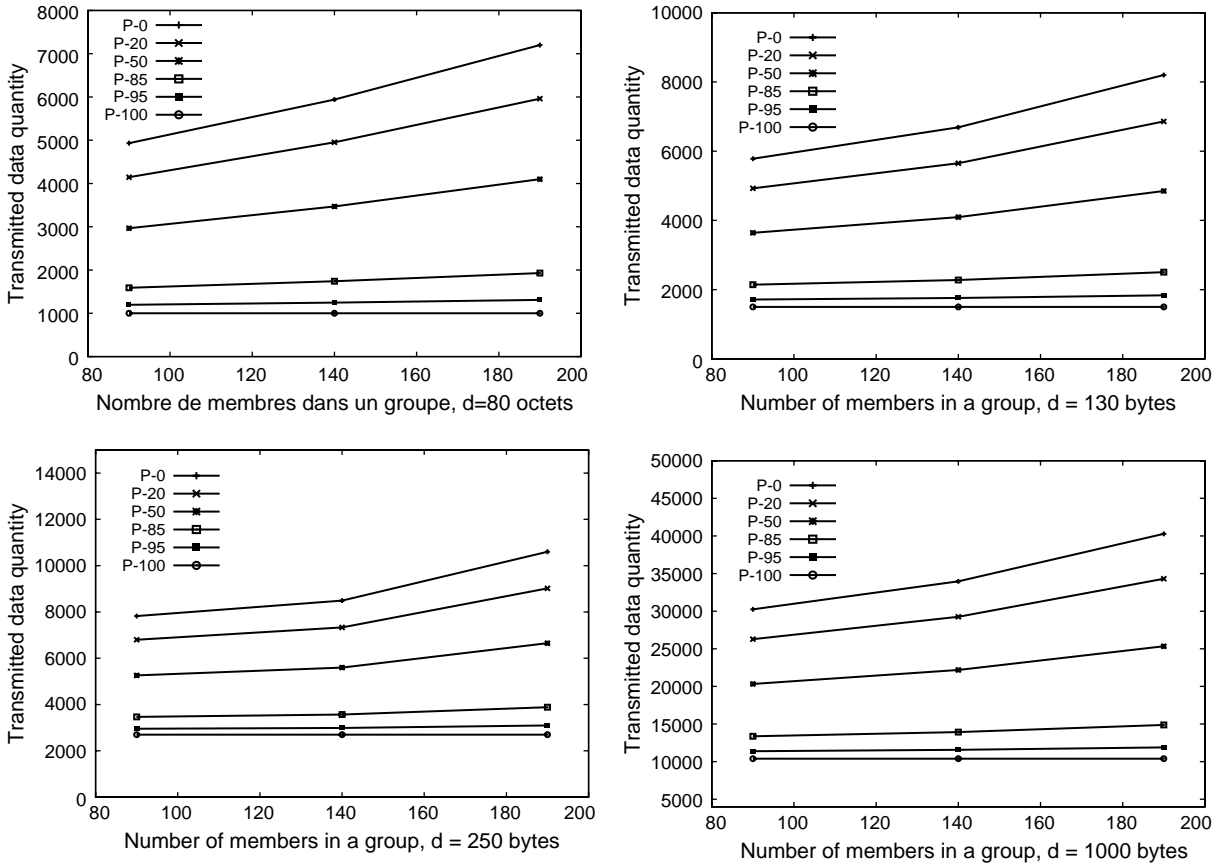
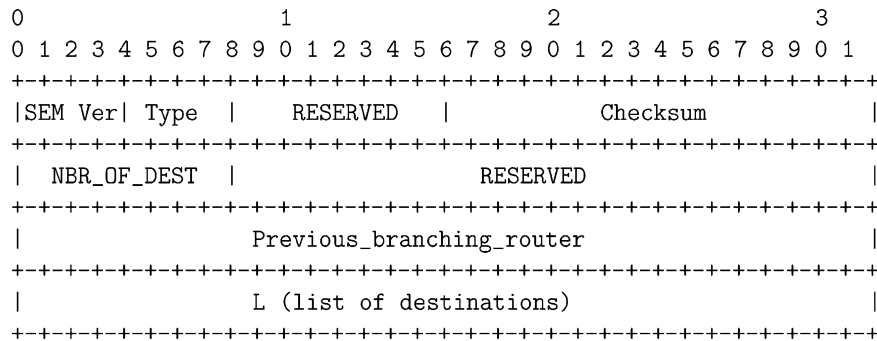

Fig. 23. The transmitted volume in the core network with protocols GXcast and SEM.

Appendix A. SEM packets headers

A.1. branch message

The SEM header of a *branch* message is described as follows:



L represents the list of destinations (field with a variable length) and is described as follows:

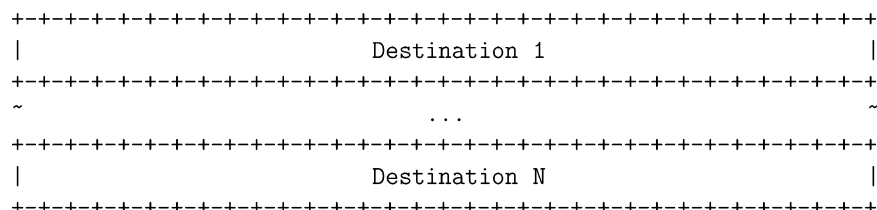

A.2. *previous_branch* message

The SEM header of a *previous_branch* is described as follows:

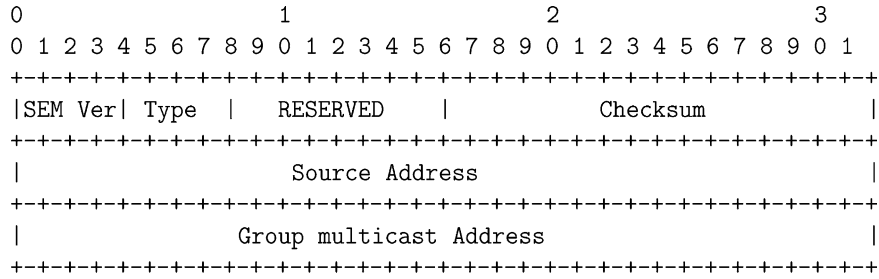

A.3. *join* message

The SEM header of a *join* is described as follows:

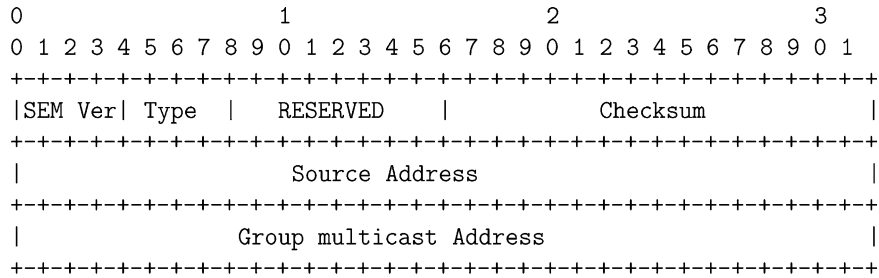

A.4. *leave* message

The SEM header of a *leave* is described as follows:

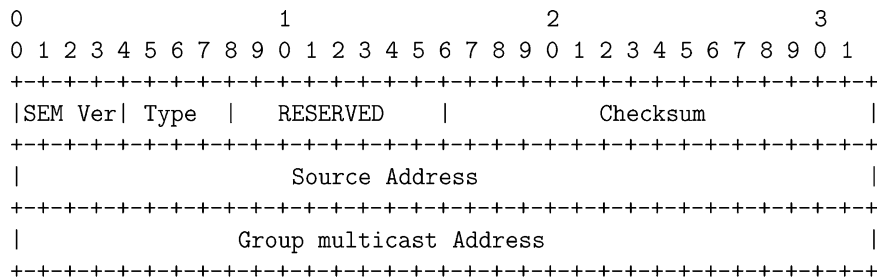

A.5. *alive* message

The SEM header of a *alive* is described as follows:

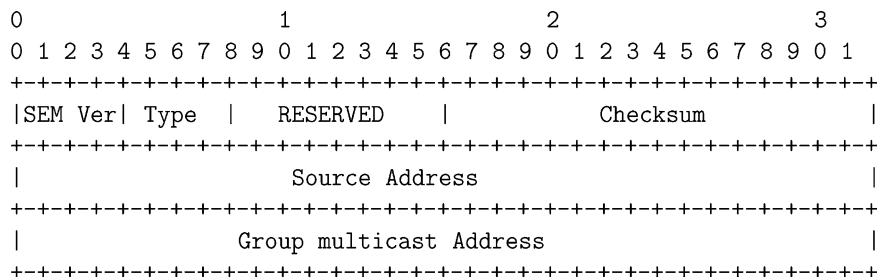

A.6. Data packet in SEM mode

The SEM header of a data packet in SEM mode is described as follows:

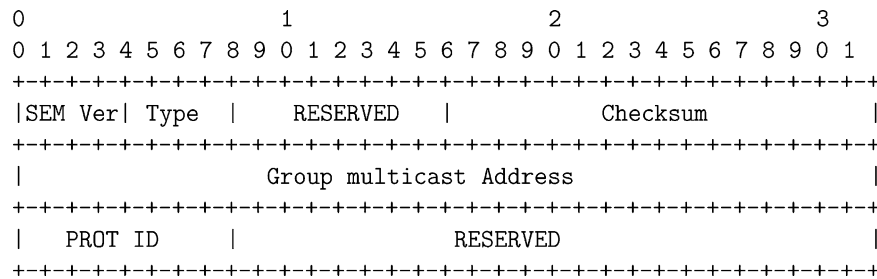

References

- [1] J. Tian, G. Neufeld, Forwarding state reduction for sparse mode multicast communication, in: INFOCOM (2) (1998) 711–719
- [2] P. Radoslavov, D. Estrin, R. Govindan, Exploiting the bandwidth-memory tradeoff in multicast state aggregation, Technical report 99-697, University of Southern California, Department of CS (July 1999).
- [3] D. Estrin, D. Farinacci, A. Helmy, D. Thaler, S. Deering, M. Handley, V. Jacobson, C. Liu, P. Sharma, L. Wei, Protocol independent multicast-sparse mode (PIM-SM): protocol specification, IETF RFC 1998; 2362.
- [4] A. Ballardie, Core based trees (CBT) multicast routing architecture, IETF RFC 1997; 2201.
- [5] R. Boivie, N. Feldman, Y. Imai, W. Livens, D. Ooms, O. Paridaens, Explicit multicast (Xcast) basic specification, IETF Internet draft (January 2003).
- [6] A. Boudani, A. Guitton, B. Cousin, GXcast: generalized explicit multicast routing protocol, in: The Ninth IEEE Symposium on Computers and Communications (ISCC 2004) (2004) 1000–1005.
- [7] I. Stoica, T. Eugene, H. Zhang, REUNITE: a recursive unicast approach to multicast, in: INFOCOM (3) (2000) 1644–1653.
- [8] L. HMK Costa, S. Fdida, O. CMB Duarte, Hop-by-hop multicast routing protocol, in: ACM SIGCOMM (2001) 249–259.
- [9] S. MyungKI, K. YongJin, P. KiShik, K. SangHa, Explicit multicast extension (Xcast+) for efficient multicast packet delivery, ETRI Journal 23 (4) (2001).
- [10] B. Cain, S. Deering, A. Thyagarajan, Internet Group Management Protocol, version 3 IETF RFC 3376 (2002).
- [11] S. Bhattacharyya, An overview of source-specific multicast (SSM), IETF RFC 2003; 3569.
- [12] H. Holbrook, B. Cain, Source-specific multicast for IP, IETF Internet draft (2003).
- [13] K. Fall, K. Varadhan, The NS Manual, UC Berkeley, LBL, USC/ISI, and Xerox PARC (January 2001).
- [14] E. Zegura, K. Calvert, S. Bhattacharjee, How to model an internet-network, IN: INFOCOM (1996) 594–602
- [15] B. Waxman, Routing of multipoint connections, IEEE Journal on Selected Areas in Communications 6 (9) (1988) 1617–1622.
- [16] G. Apostolopoulos, R. Guerin, S. Kamat, S. Tripathi, Quality of service based routing: a performance perspective, in: ACM SIGCOMM (1998) 913–919.
- [17] J. Farber, Network game traffic modelling, in: The First Workshop on Network and System Support for Games (Netgames), 2002.
- [18] W. Feng, F. Chang, W. Feng, J. Walpole, Provisioning online games: a traffic analysis of a busy counter-strike server, in: The Second ACM SIGCOMM Workshop on Internet Measurement, 2002.