

On the Relationship between Use Case Maps and Message Sequence Charts

Francis Bordeleau, Carleton University
Donald Cameron, Nortel Networks

Outline

- **Motivation**
- **Overview of a proposed development process**
- **Problem**
- **Introduction to UCM**
- **Conceptual relationship between UCM and MSC**
- **Transition from UCM to MSC**
- **Conclusion**

Motivations

- **Telecommunication standards are becoming more and more important as the pressure to deliver the unified network to every corner of the globe grows.**
- **Delays are being met with increasing impatience.**
- **Test-based specifications are too open to interpretation**
- **As features and feature interactions become more complex, the specifications become more difficult to comprehend**
- **MSC-like notations are being used as a way to analyze user requirements**
- **UCMs introduced in WIN standards to express user requirements**

Motivations

- **Nortel WIN people have proposed a scenario-driven design process and are asking that the notations used in this process be connected together by transformations; this is key to reducing Time-To-Market**

Proposed Development Process

Requirements

Use Case 1

Use Case 2

Use Case 3

Stage 1
UCM

Stage 2
MSC

Stage 3
SDL

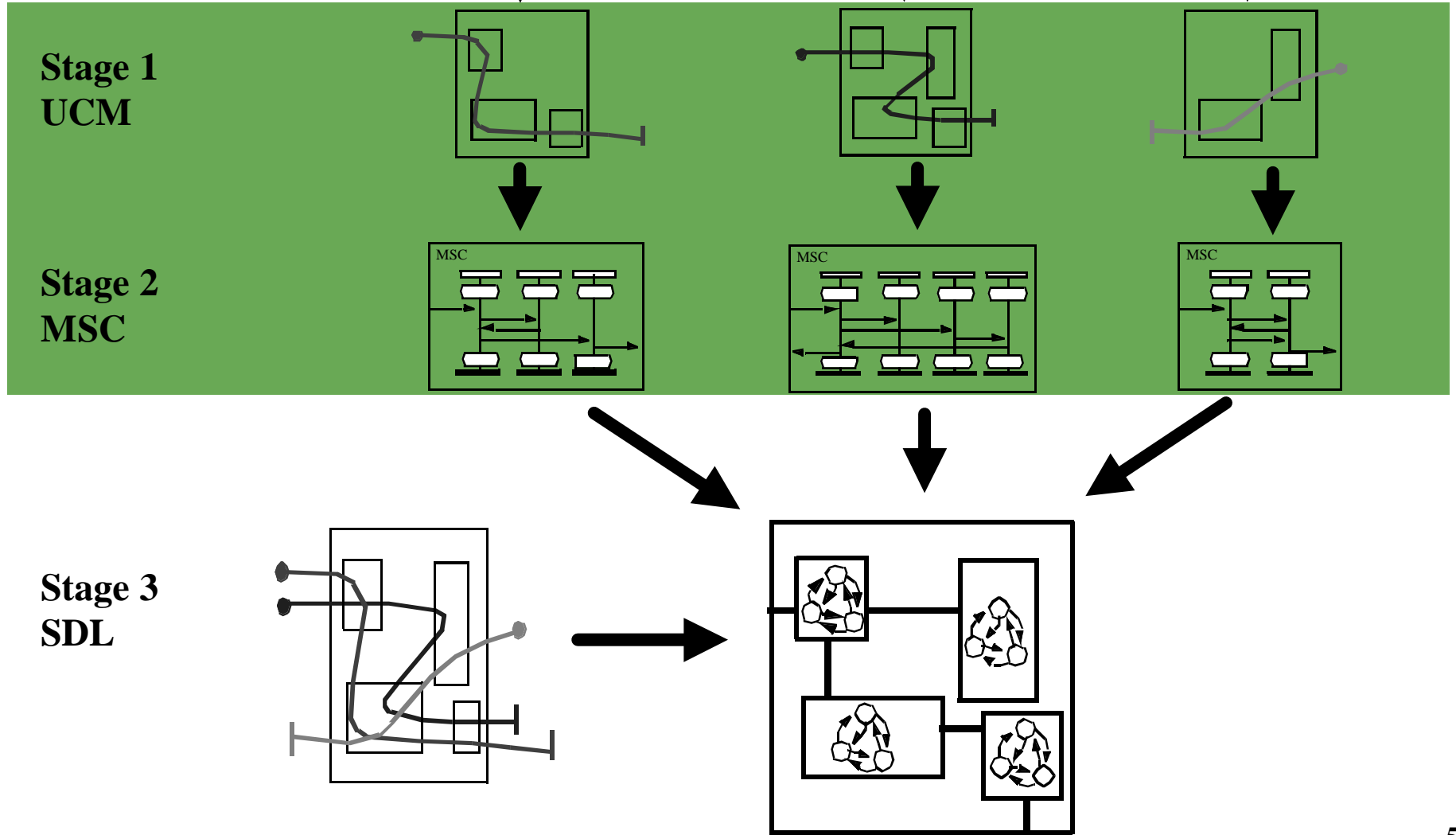

Problem

- **How do we combine those different modeling techniques in a consistent and traceable manner?**
- **Semantics issues**
- **In this presentation, we focus on the transition between UCM and MSC**

Use Case Maps

- **Notation developed at Carleton University by Ray Buhr, colleagues and students**
- **UCM allows:**
 - **Definition of scenarios at an abstract level (before inter-component messaging is defined)**
 - **Superimposition of scenarios on system structure**
 - **Combination of sets of scenarios in a single diagram**
 - **Description of system dynamics both at the component level and at the scenario level**

Basic UCM Notation

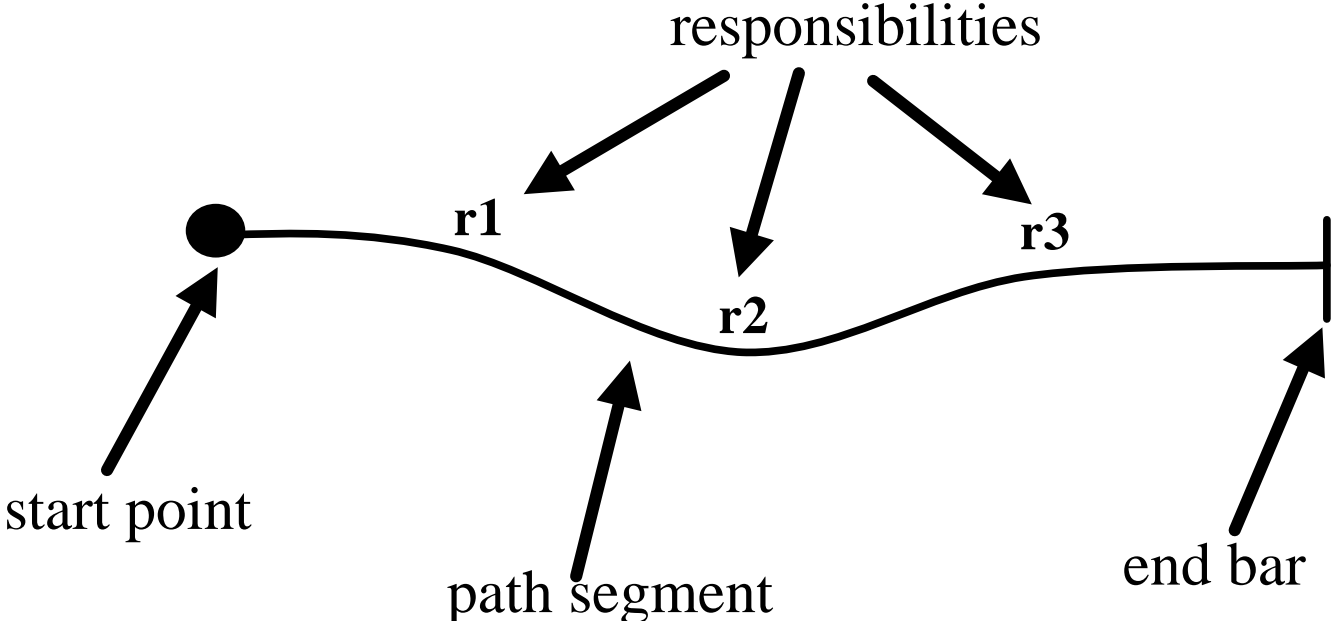

Waiting Places and Stub

Waiting Place



Timed waiting place, or timer

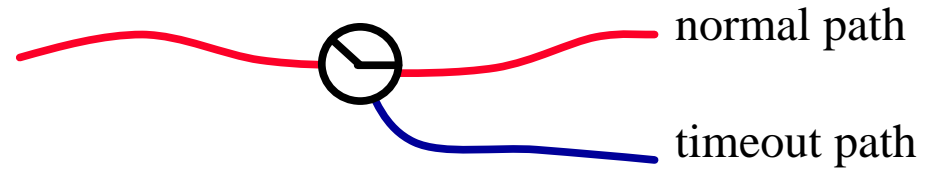

UCM provides a path abstraction mechanism called *stub*

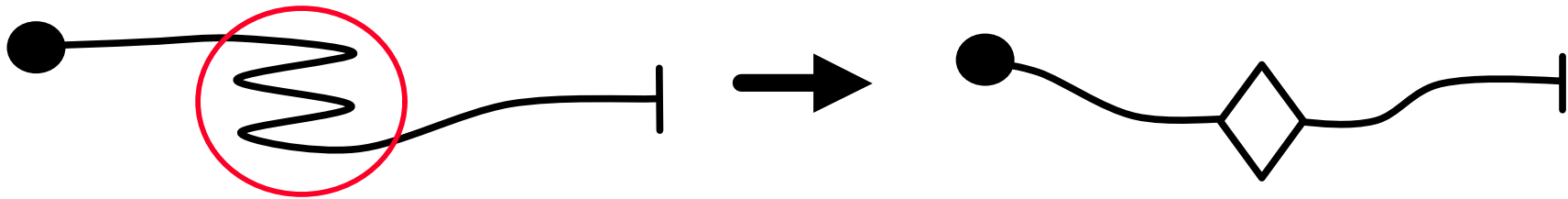

Bound UCM

UCM allows describing scenarios in the context of component structures

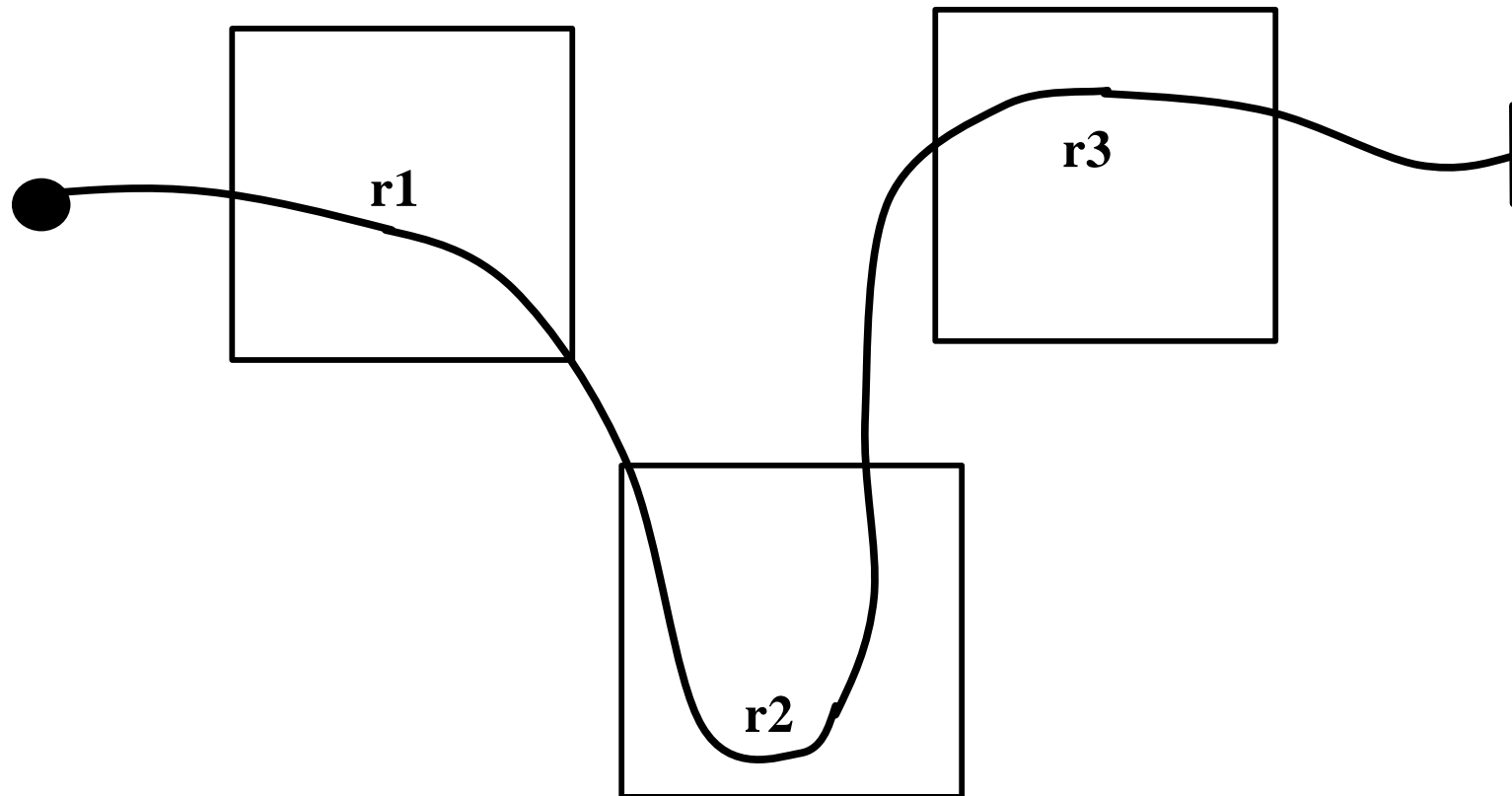

Bank Machine UCM

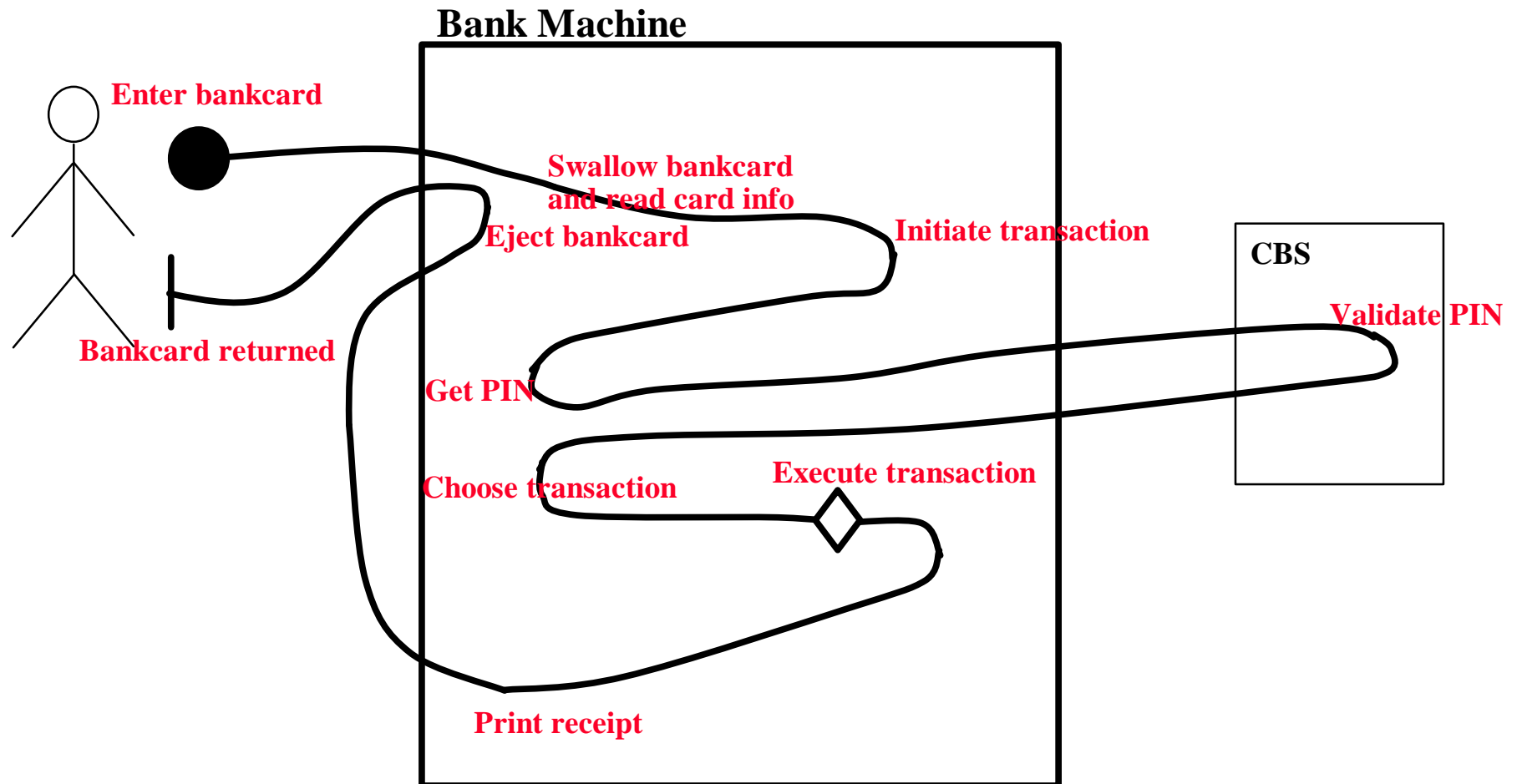

Bank Machine UCM

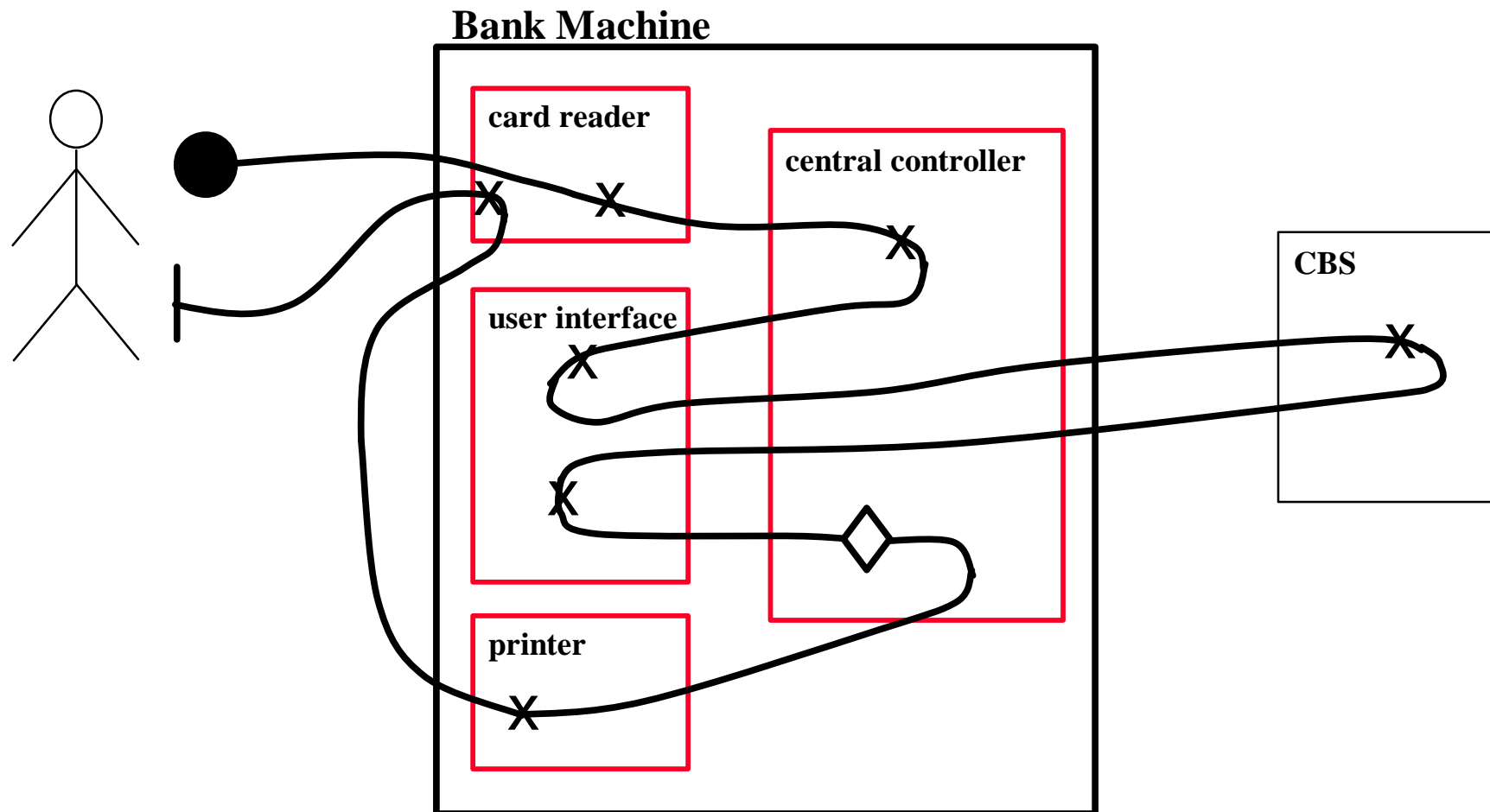

Path Segment Connectors

Path Segment Connectors

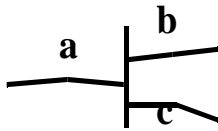

AND-fork

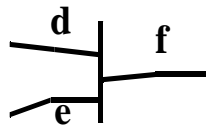

AND-join

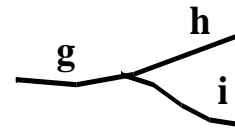

OR-fork

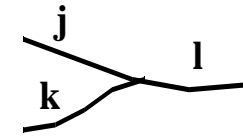

OR-join

Combination of Segment Connectors

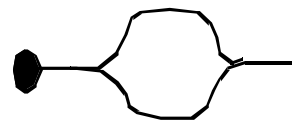
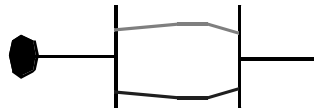

Related Paths Set

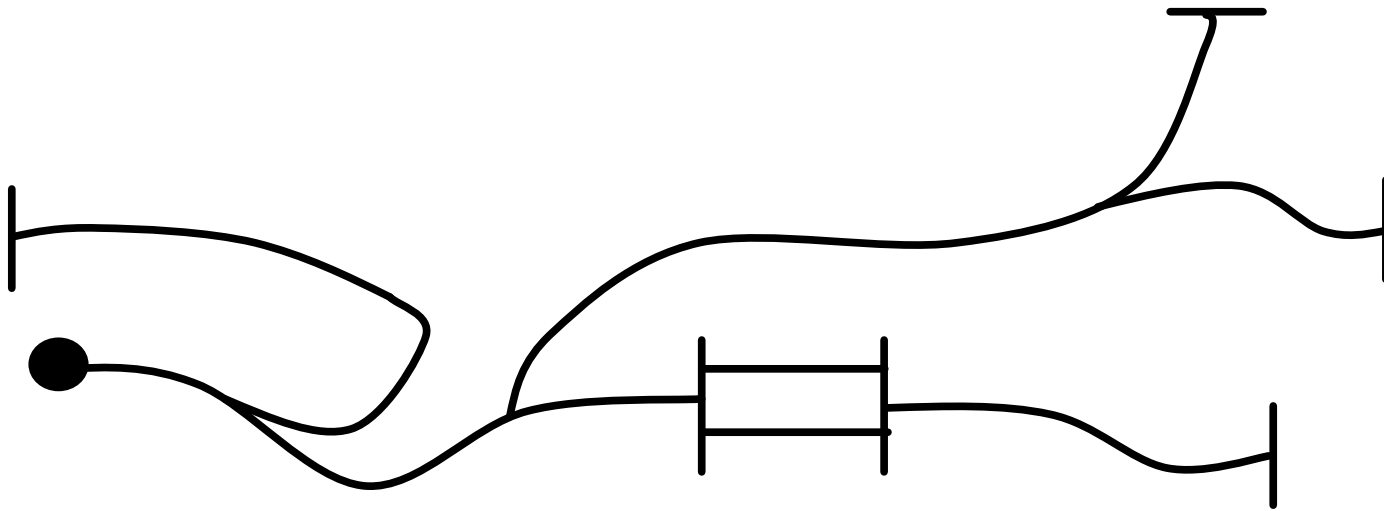

Group together in logical unit a main path with the set of its alternatives

Bank Machine UCM

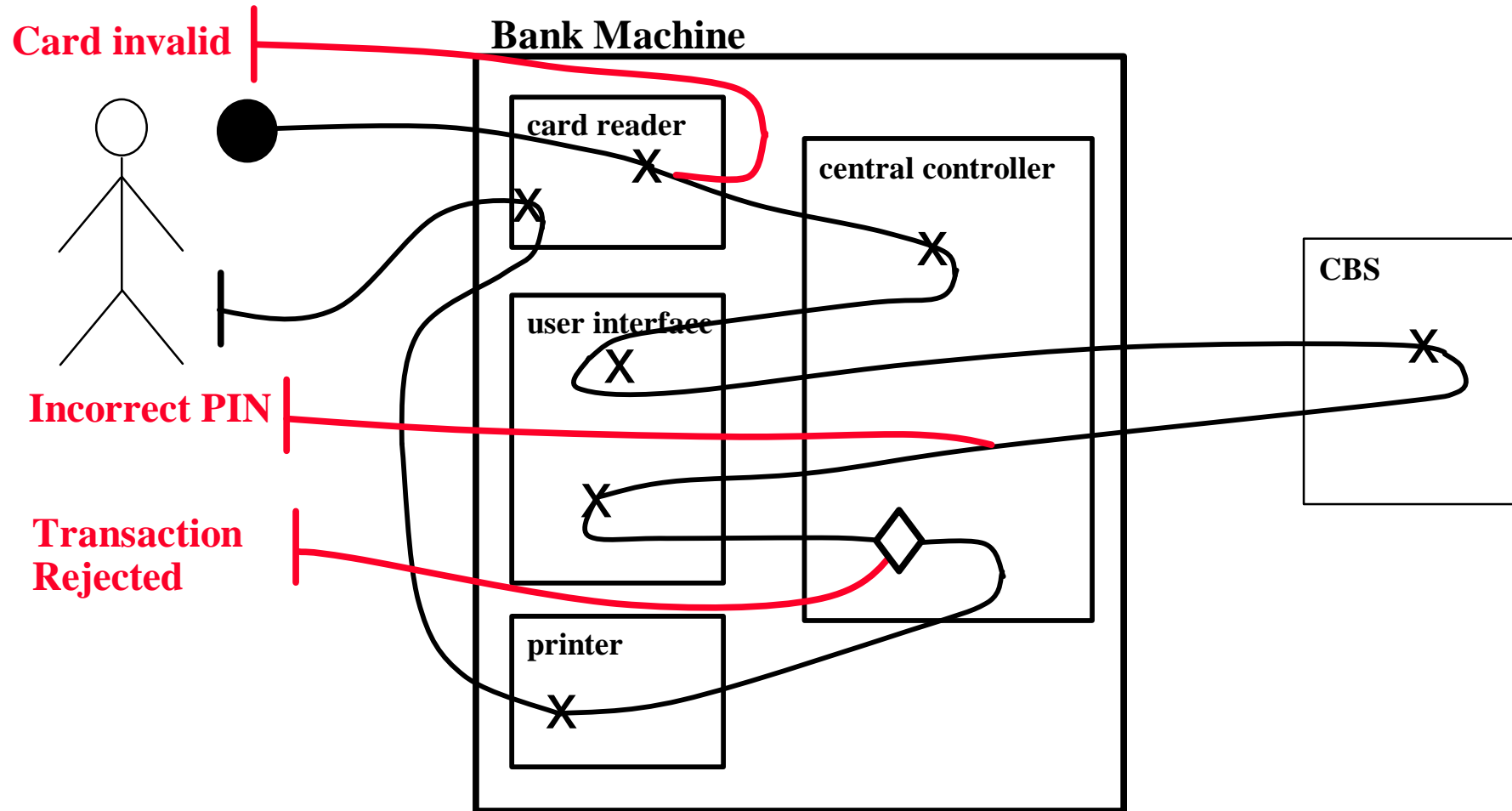

Path Interaction Notation

Asynchronous Interactions

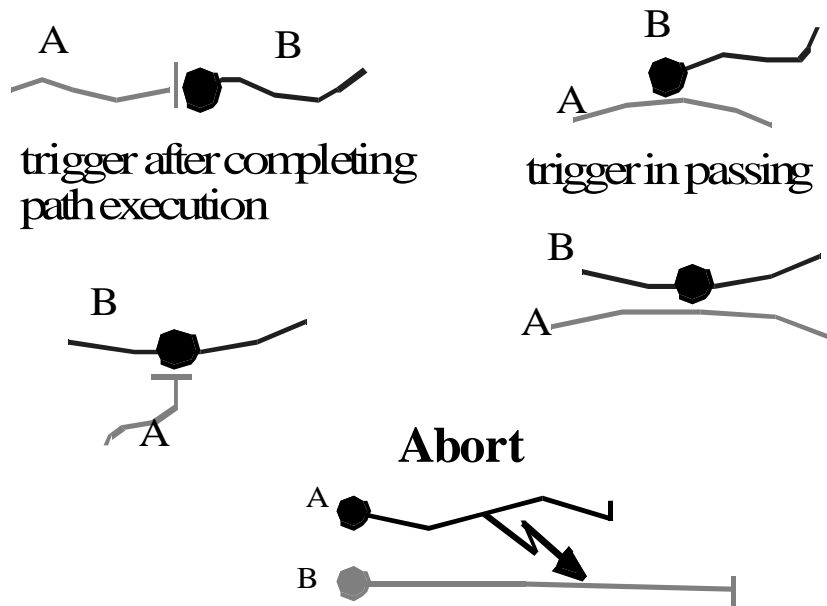

Synchronous Interactions

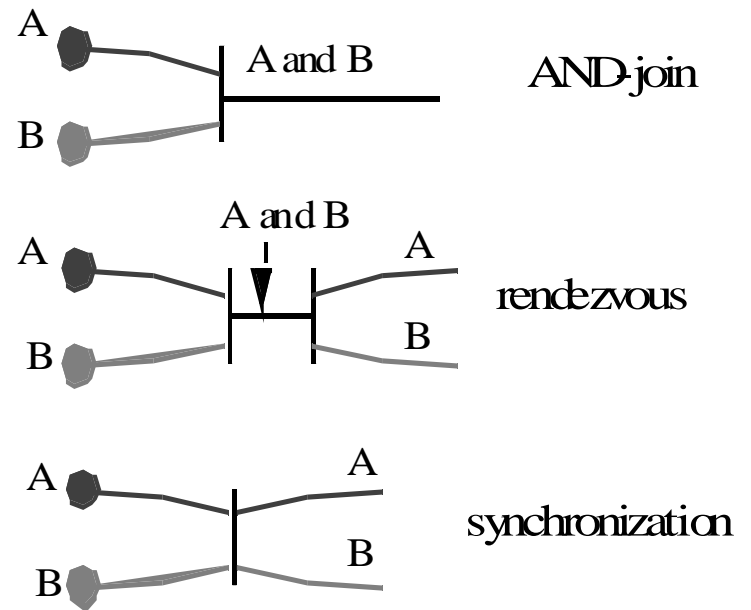

More Complex UCM

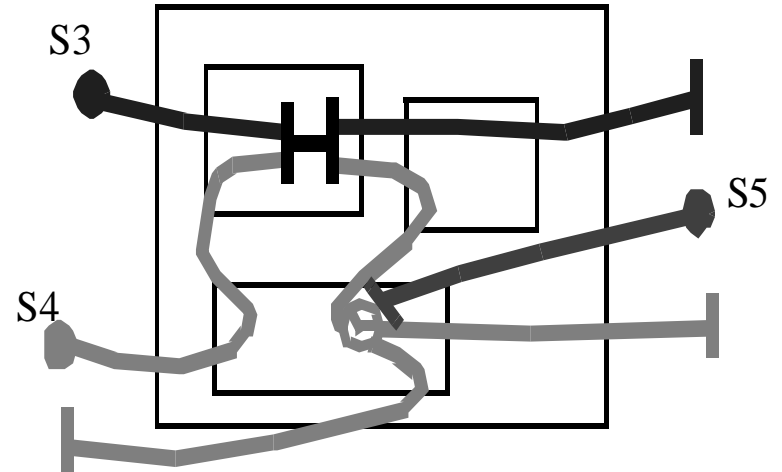
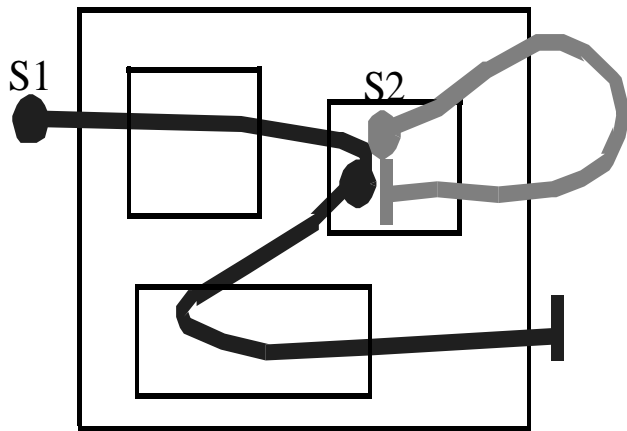

Relationship between UCM and MSC

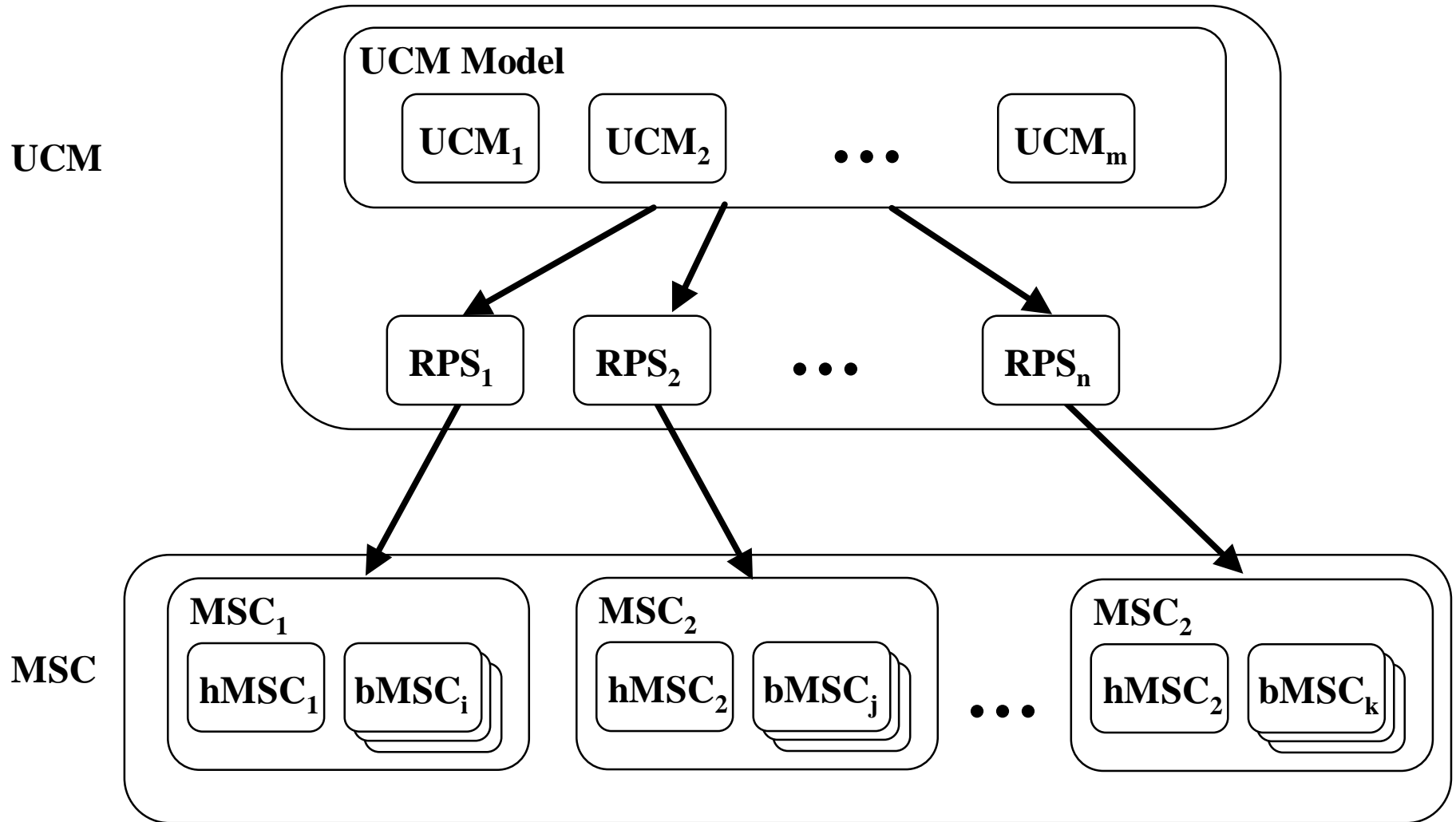

Relationship between UCM and MSC (2)

At the detailed level, we establish relationships between:

- **UCM components and MSC instances**
- **UCM preconditions and postconditions and MSC conditions (expressing global states)**
- **UCM responsibilities and MSC sequences of messages, actions and methods**
- **UCM path segments and basic MSCs (and MSC references)**
- **UCM path connectors and HMSC alternative and parallel composition constructs (MSC reference connectors) or inline expressions**
- **UCM stubs and MSC references**

Transition between UCM and MSC

The transition between UCM and MSC is conducted in three steps:

- 1. Generation of HMSCs**
- 2. Generation of basic MSC skeletons**
- 3. Definition of message sequences**

Generation of HMSC

UCM RPS1

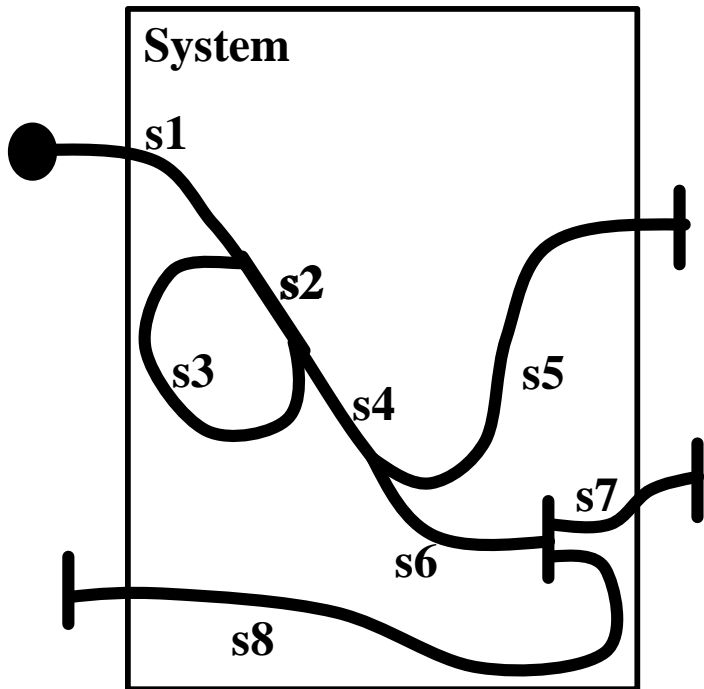

HMSC RPS1

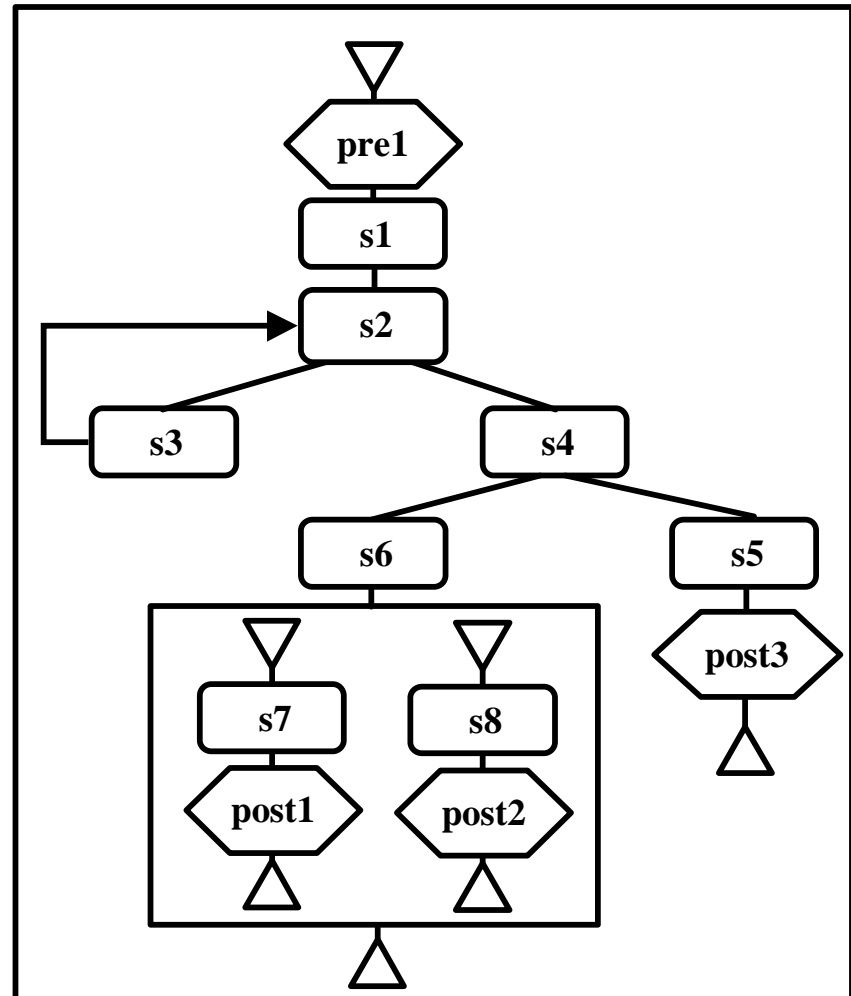

Generation of Basic MSC Skeletons

ucm S1

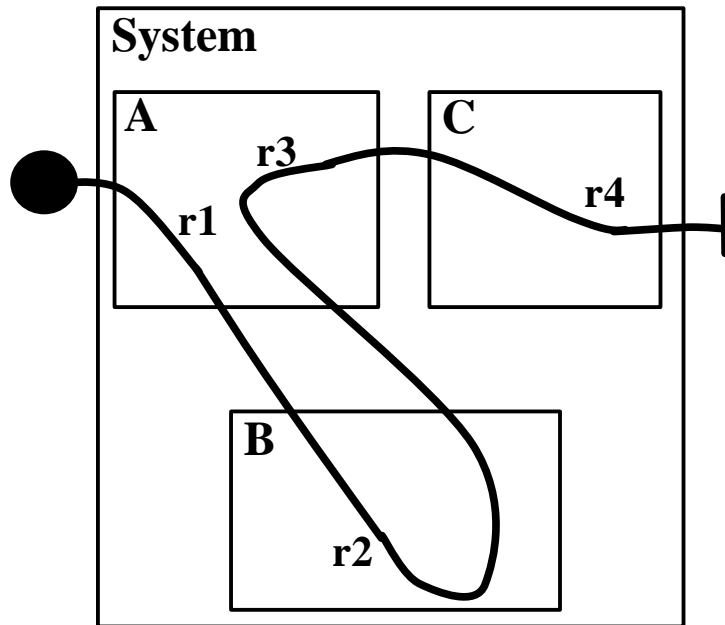

msc S1

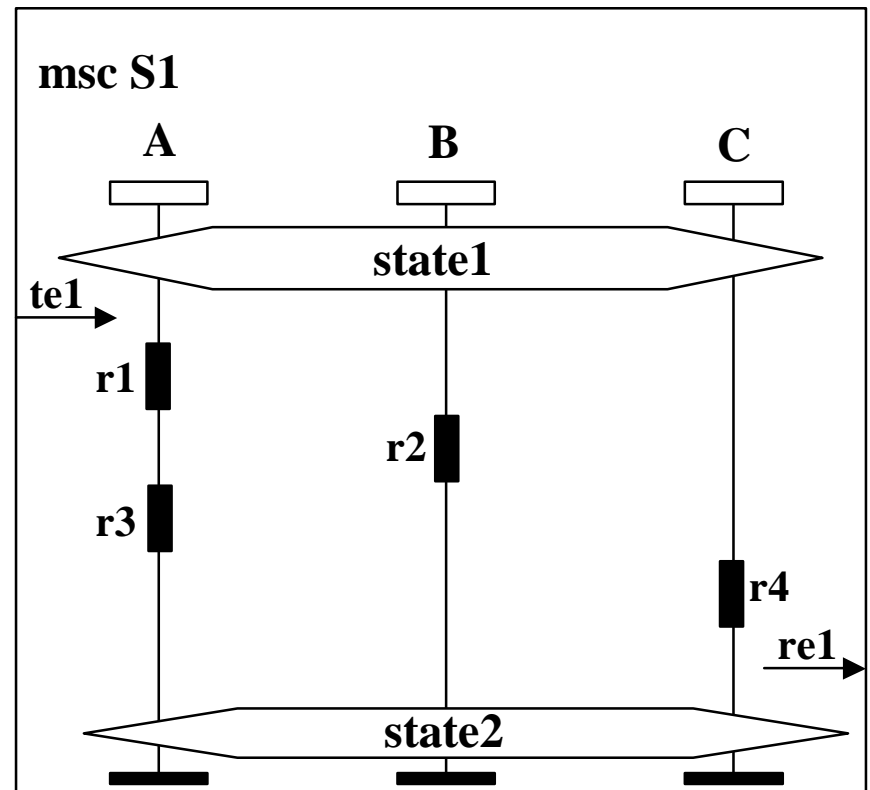

Definition of Message Sequences

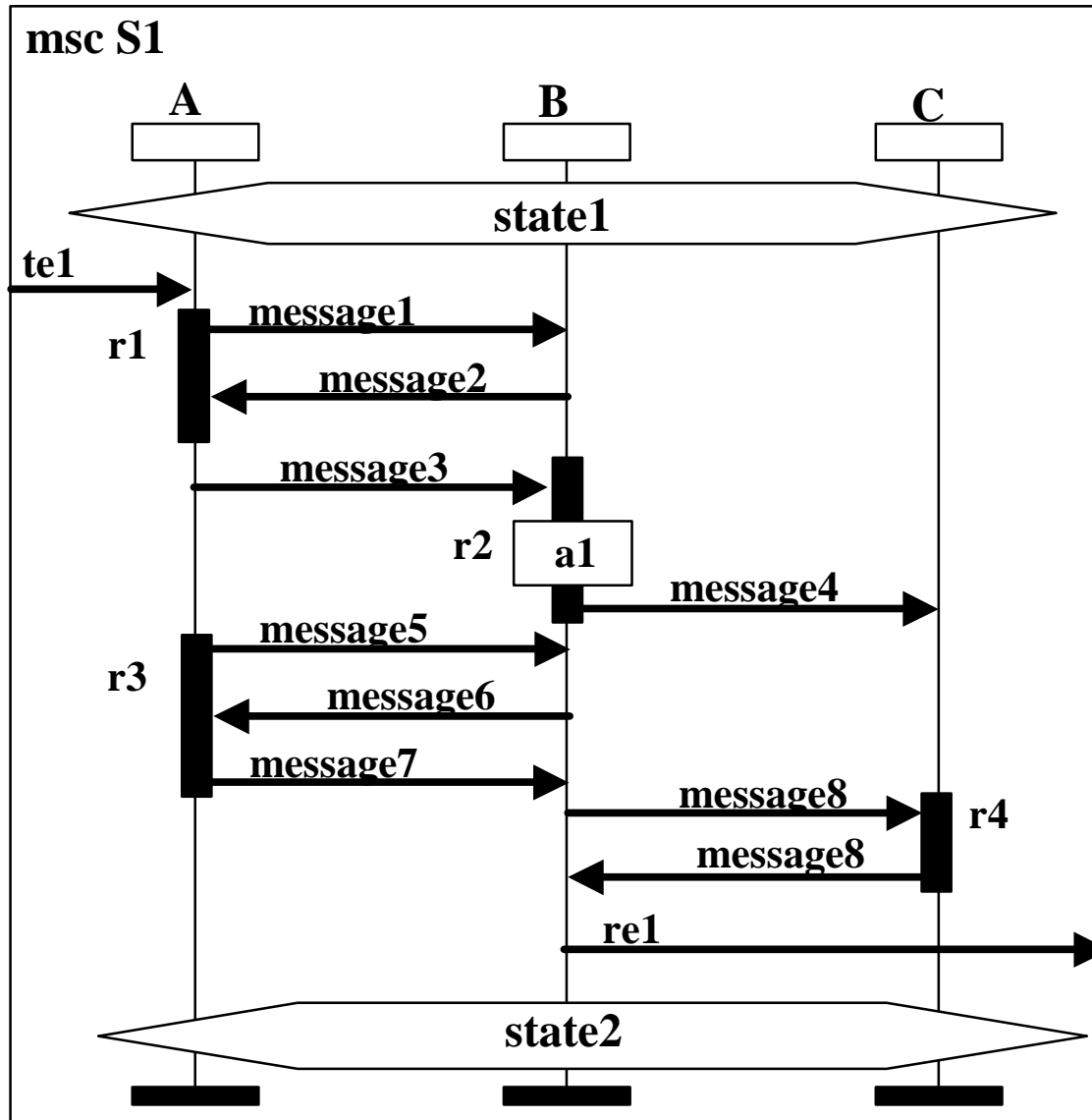

Experience with UCM and MSC

- **UCMs generated using the UCM Navigator tool have been used in the WIN standard**
- **MSC-like notations generated using drawing tools have been used in the WIN standard**
- **We have generated skeleton MSCs from UCMs using the UCM Navigator tool and Telelogic's Tau tool**
- **UCMs have been used in Nortel projects since 1994**

Future Work

- **Backwards-looking consistency**
 - Generation of a UCM from a set of MSCs
- **Extension of forward-looking semi-automated transformation**
 - Generation of an SDL model from a set of MSCs

Conclusion

- **MSCs and SDLs are standard notations; Nortel wants a requirements notation that is also a standard**
- **Nortel has proposed a new question to Study Group 10, Question 12/10 on User Requirements Notation**
- **Nortel wants the Use Case Map notation to be given rigorous scrutiny in the ITU standards forum**
- **We are going to demonstrate the UCM to MSC transformations to the WIN standards community**

References

Use Case Maps website:
www.usecasemaps.org