

Network Fusion

Pascal Fradet¹ and **Stephane Hong Tuan Ha**²

¹ INRIA Rhone-Alpes

Pascal.Fradet@inria.fr

² IRISA/INRIA Rennes

shongtua@irisa.fr

Context and Motivation

- ▶ Component programming
 - ▶ Advantages : readability, maintainability, separate development
 - ▶ Disadvantages : efficiency issues
- ▶ Filter Fusion
 - ▶ Proposed by Proebsting and Watterson at POPL'96
 - ▶ Program transformation to fusion filters in pipeline with a particular scheduling strategy
- ▶ Our work: extend Filter Fusion to
 - ▶ General networks
 - ▶ User-defined scheduling strategies

Network Fusion

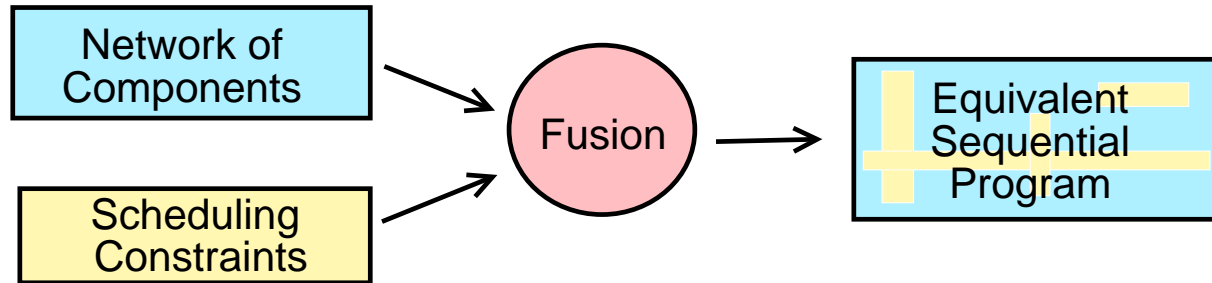

- ▶ Efficient implementation of networks of components
 - ▶ Compiles and removes context switches and communication channels
- ▶ Generalizes and formalizes filter fusion
 - ▶ Based on LTS, synchronized product, and static analyses
- ▶ Inspired from AOP
 - ▶ Keeps functionality and scheduling issues separate
 - ▶ Can be seen as weaving synchronisation aspects

Overview

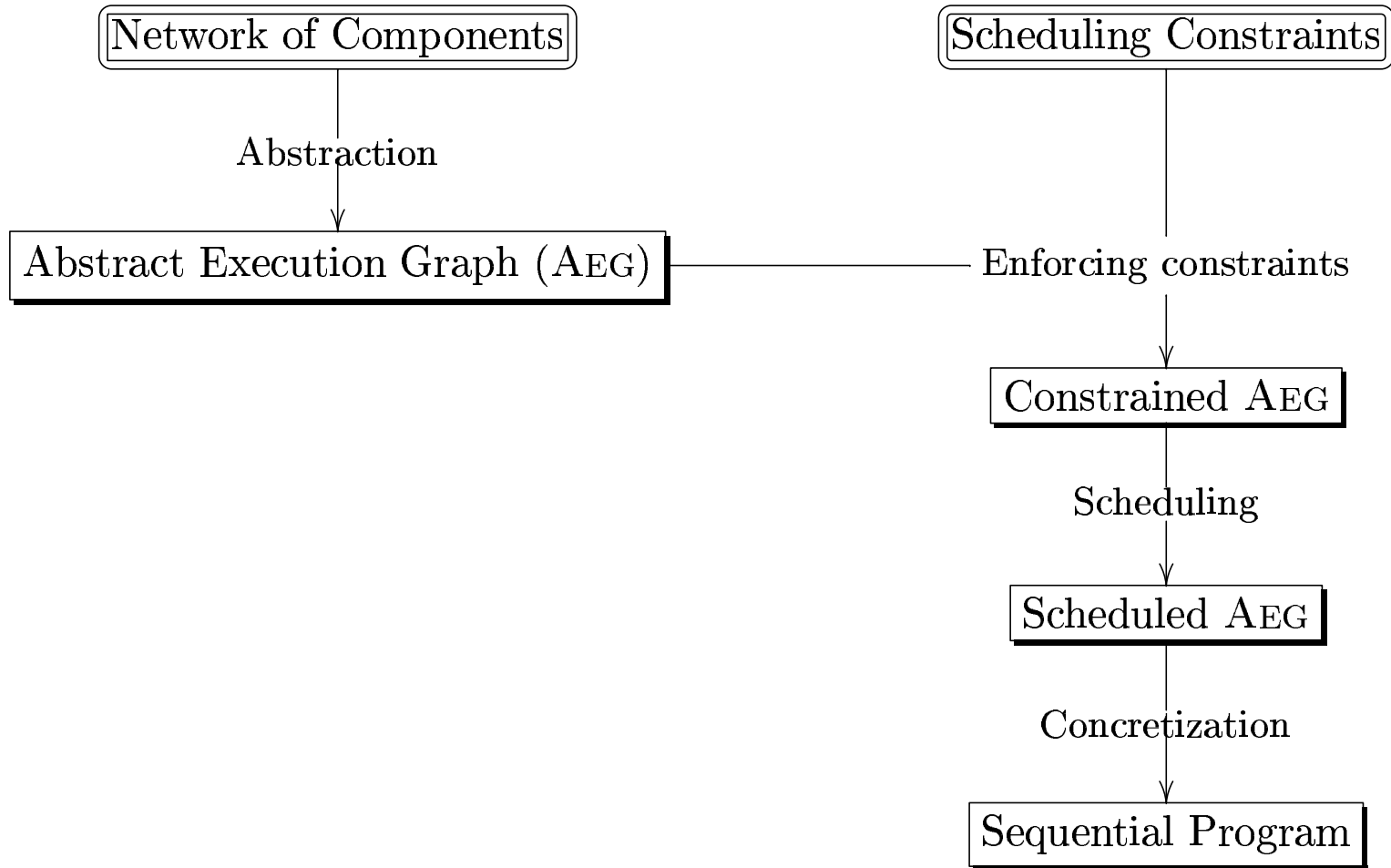

Component Model

- ▶ Based on Kahn Process Network (KPN)
 - ▶ Simple and formal model
- ▶ Main features:
 - ▶ Set of asynchronous communicating processes
 - ▶ Unbounded FIFO-based communication channels
 - ▶ Non-blocking write, blocking read (on an empty channel)
 - ▶ At most one producer and one consumer
- ▶ Main properties:
 - ▶ Deterministic
 - ▶ Hierarchical

Component Language

- ▶ Definition of components by commands of the form :

$$\text{Commands} ::= l_1 : G \mid A \rightsquigarrow l_2$$

where l_1, l_2 denote labels, G a guard, and A an action.

- ▶ Actions ::= $f?x$ read x on channel f
| $f!x$ write x on channel f
| I internal action (e.g. $x:=x+1$)

Example - Network of Components

► Network :

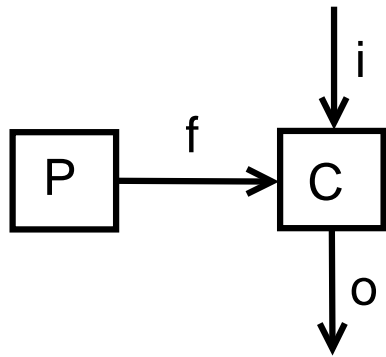

► Components :

$$P = \left\{ \begin{array}{l} p_0 : x := x + 1 \quad \rightsquigarrow \quad p_1; \\ p_1 : f!x \quad \rightsquigarrow \quad p_0 \end{array} \right\}$$

$$C = \left\{ \begin{array}{l} c_0 : a < b \mid f?a \quad \rightsquigarrow \quad c_1; \\ c_0 : a \geq b \mid \iota?b \quad \rightsquigarrow \quad c_1; \\ c_1 : o!(a + b) \quad \rightsquigarrow \quad c_0 \end{array} \right\}$$

Semantics of networks

- ▶ Operational semantics given by a LTS where
 - ▶ States represent program points of process, associations (variable \rightarrow value) and (channel \rightarrow file)
 - ▶ Transitions represent one execution step
- ▶ Example

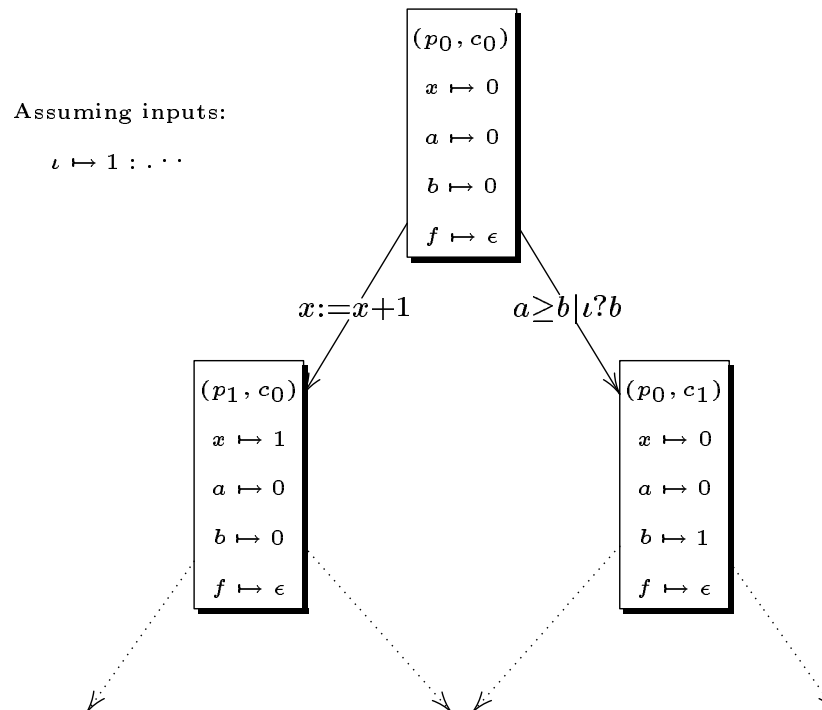

Overview

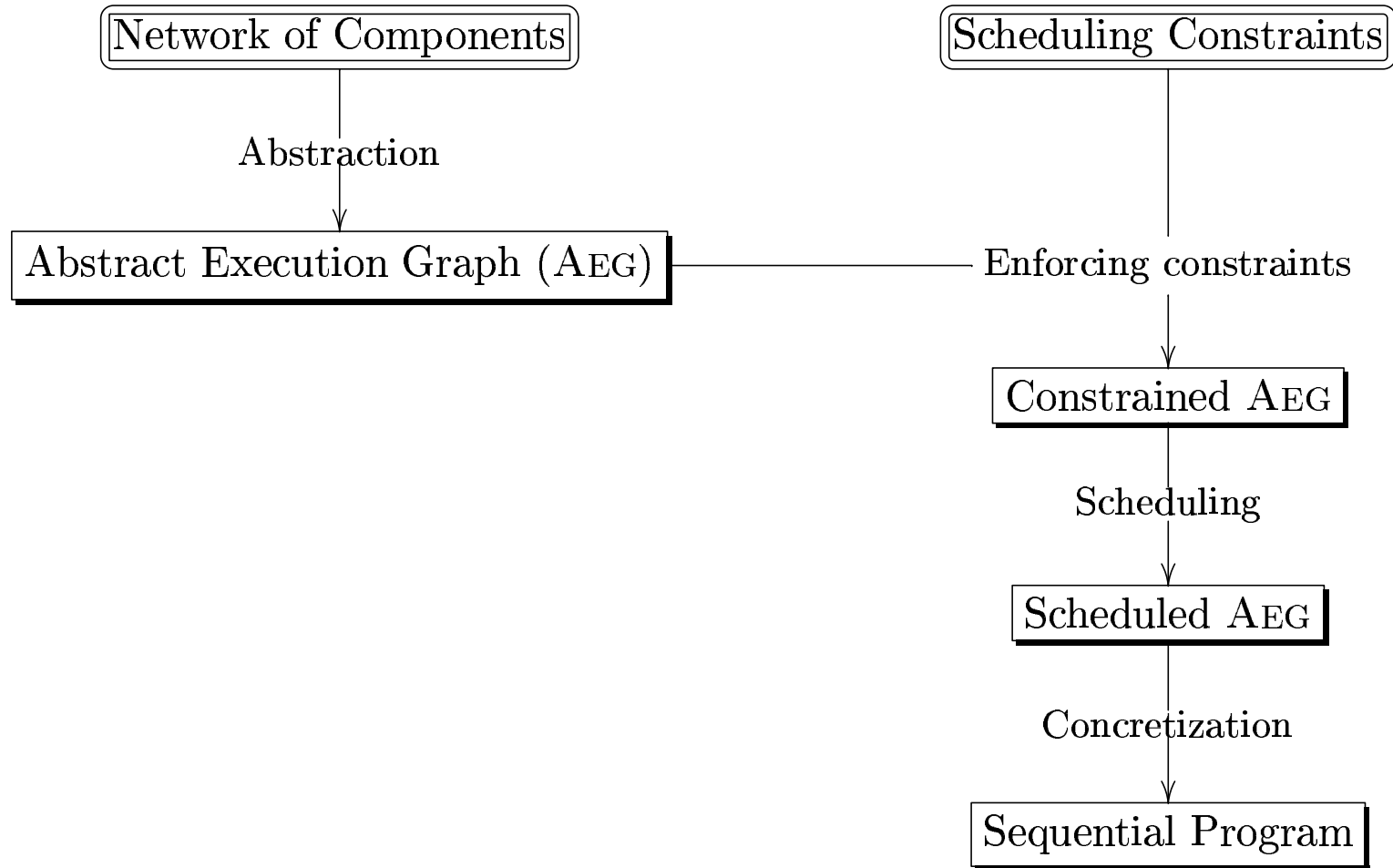

Abstract Execution Graph (AEG)

- ▶ Finite model upper-approximating all the possible execution of the KPN
 - ▶ Based on abstract interpretation techniques
- ▶ Must satisfy a few properties (safety, ...)
- ▶ Several abstractions possible (size against accuracy, more precise \Rightarrow larger AEG)

Example - AEG

- ▶ Abstraction of states into
 - ▶ Currents program point of each component
 - ▶ Intervals approximating the size of each channel

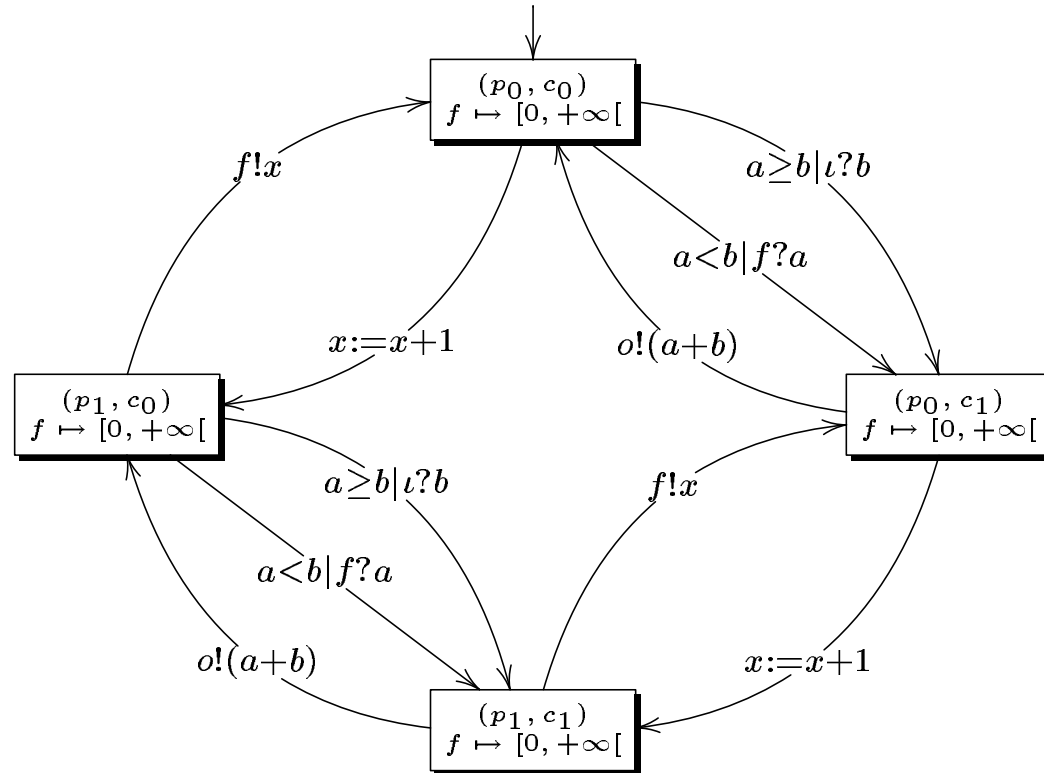

Overview

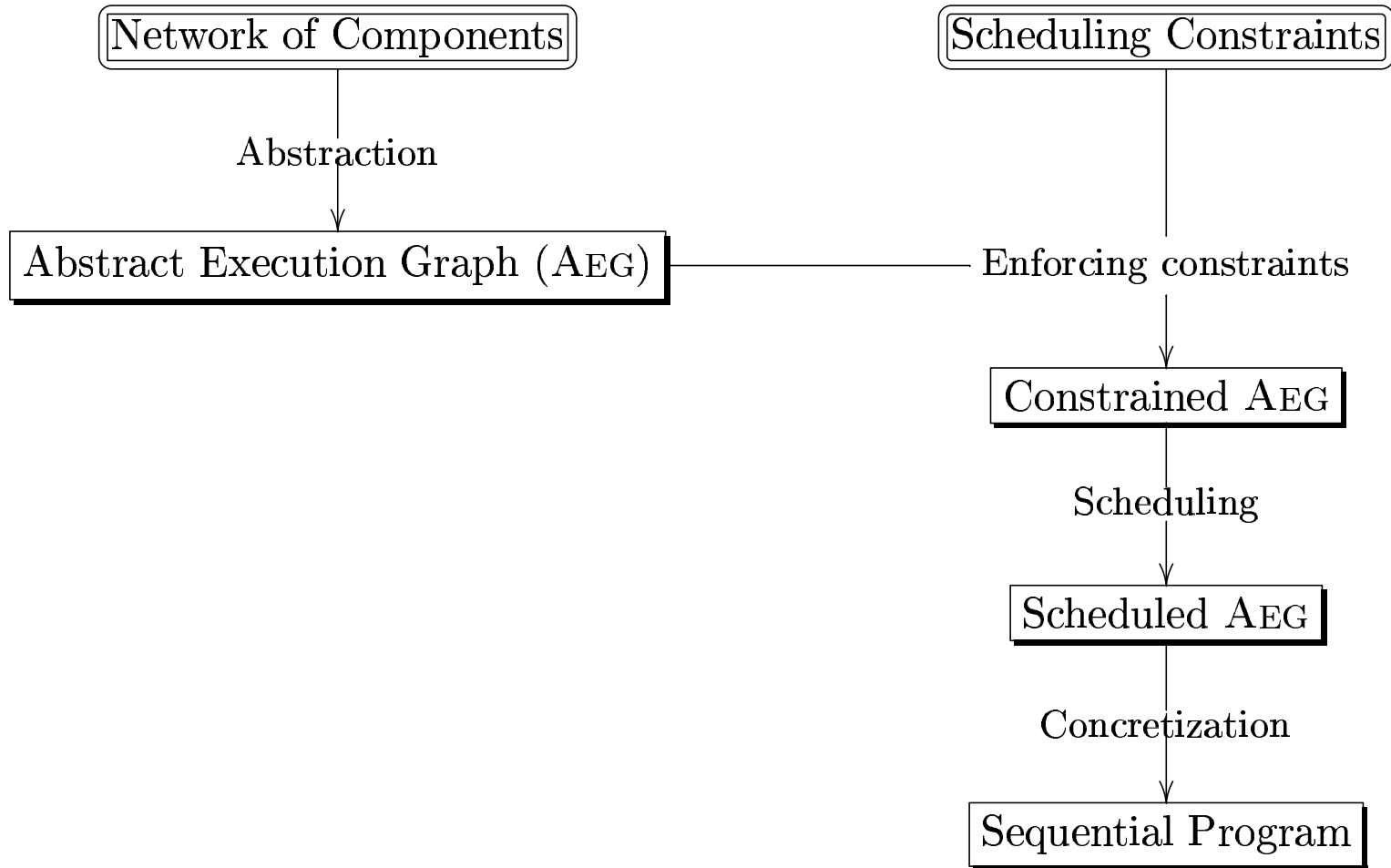

Scheduling constraints

- ▶ Specify the set of allowed executions
- ▶ Expressed with respect to
 - ▶ IO operations
 - ▶ Sizes of files
 - ▶ ...
- ▶ From no constraint to a complete sequentialization of the execution
- ▶ Benefits :
 - ▶ impose implementation choices (e.g. bounding a fifo channel)
 - ▶ guide and optimize the fusion process

Specifying constraints

- ▶ Expressed by a LTS labeled with guarded actions
- ▶ Example :

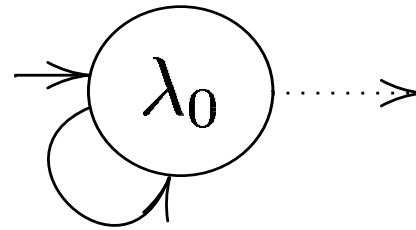

$$\overline{f} < k - 1 \mid f! \quad (\neg f!) P$$

- ▶ $f!$: any write on channel f
- ▶ $(\neg A)$: all operations except A
- ▶ $(A)_p$: projection of A onto commands of process p
- ▶ $\overline{f} < k \mid A$: all actions A provided that the size of channel f is less than k

Example - Scheduling Constraints

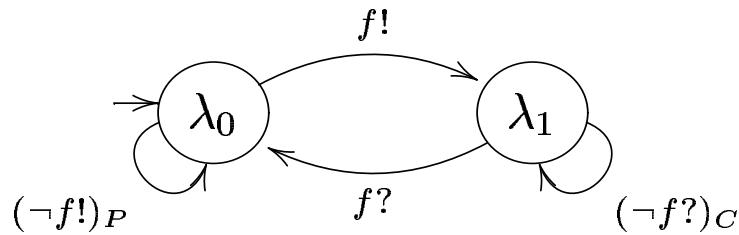

The Filter Fusion Strategy (Λ_{FF})

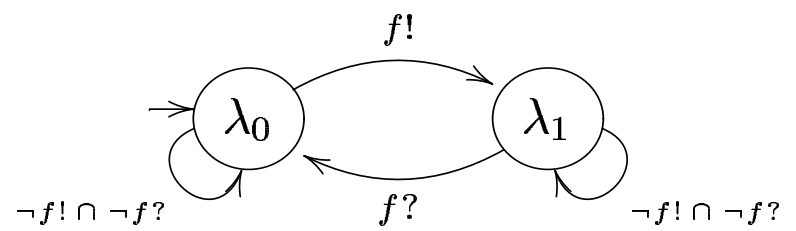

A Simple Incomplete Strategy (Λ_{IS})

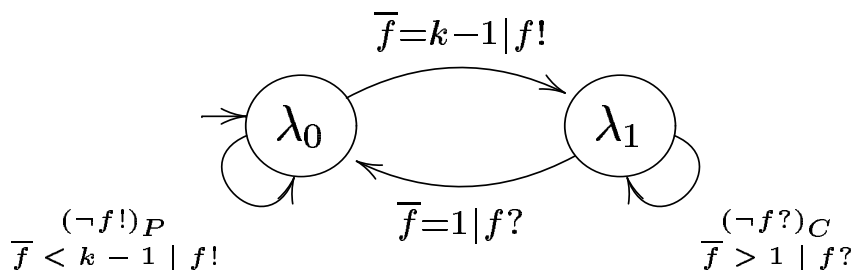

A Filter Fusion Strategy with Bounds (Λ_{FFB})

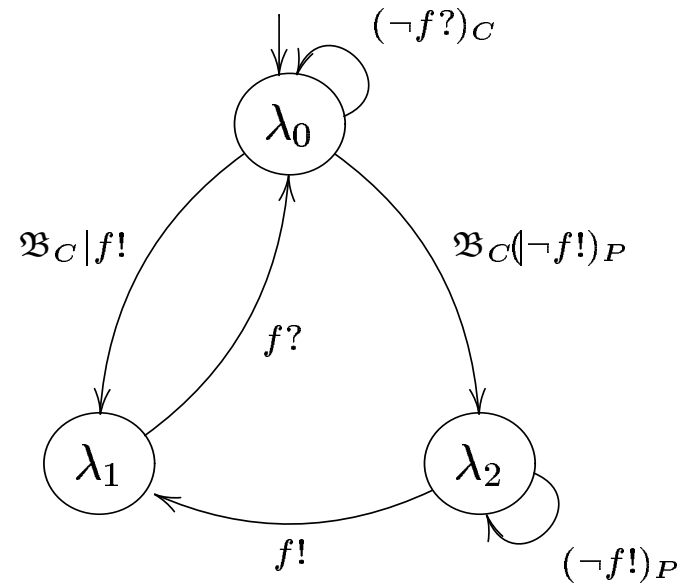

A Demand Driven Strategy (Λ_{DD})

Overview

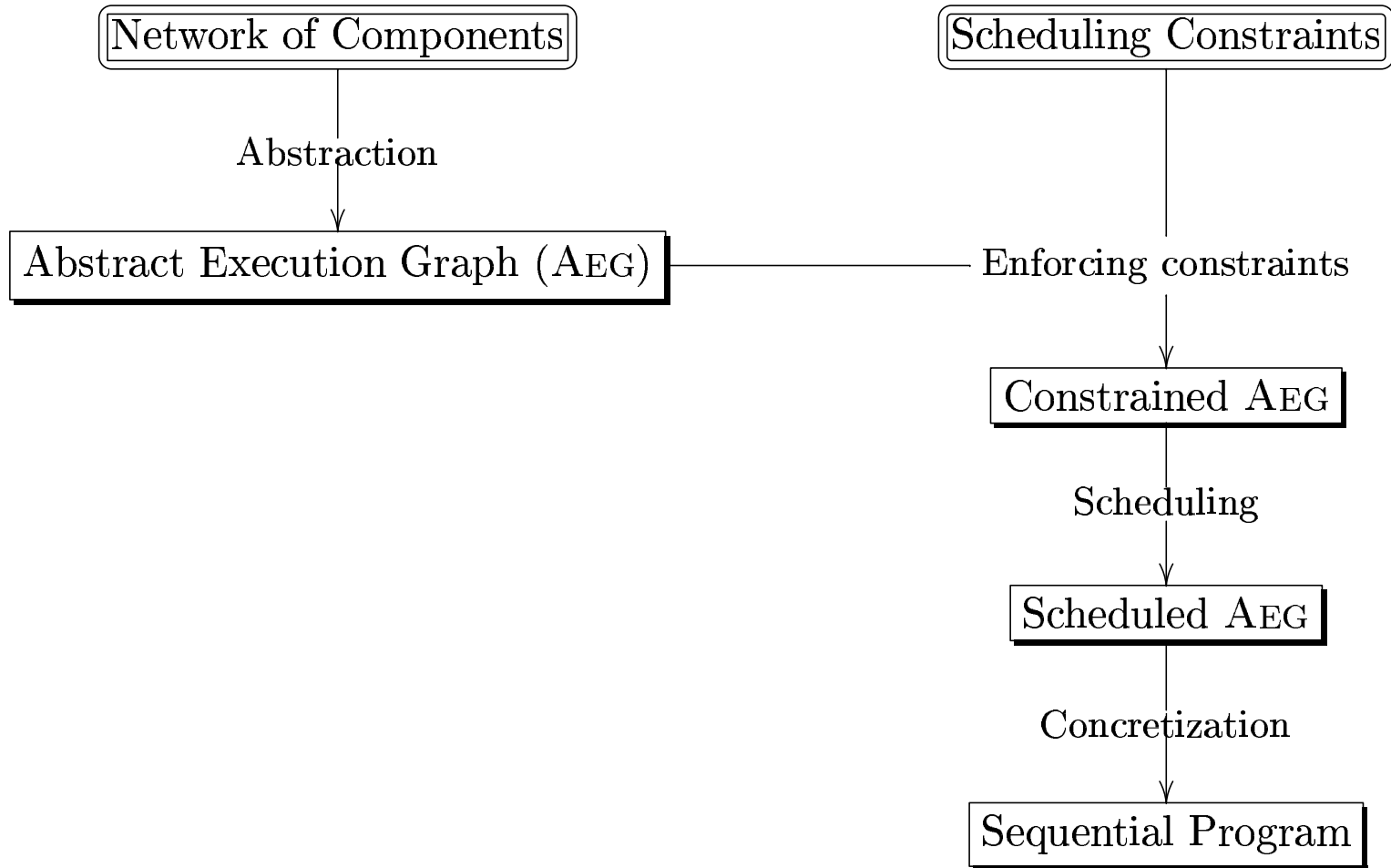

Enforcing constraint

- ▶ "Synchronized product" between AEG and constraints
- ▶ Example: $Aeg \parallel \Lambda_{FF}$

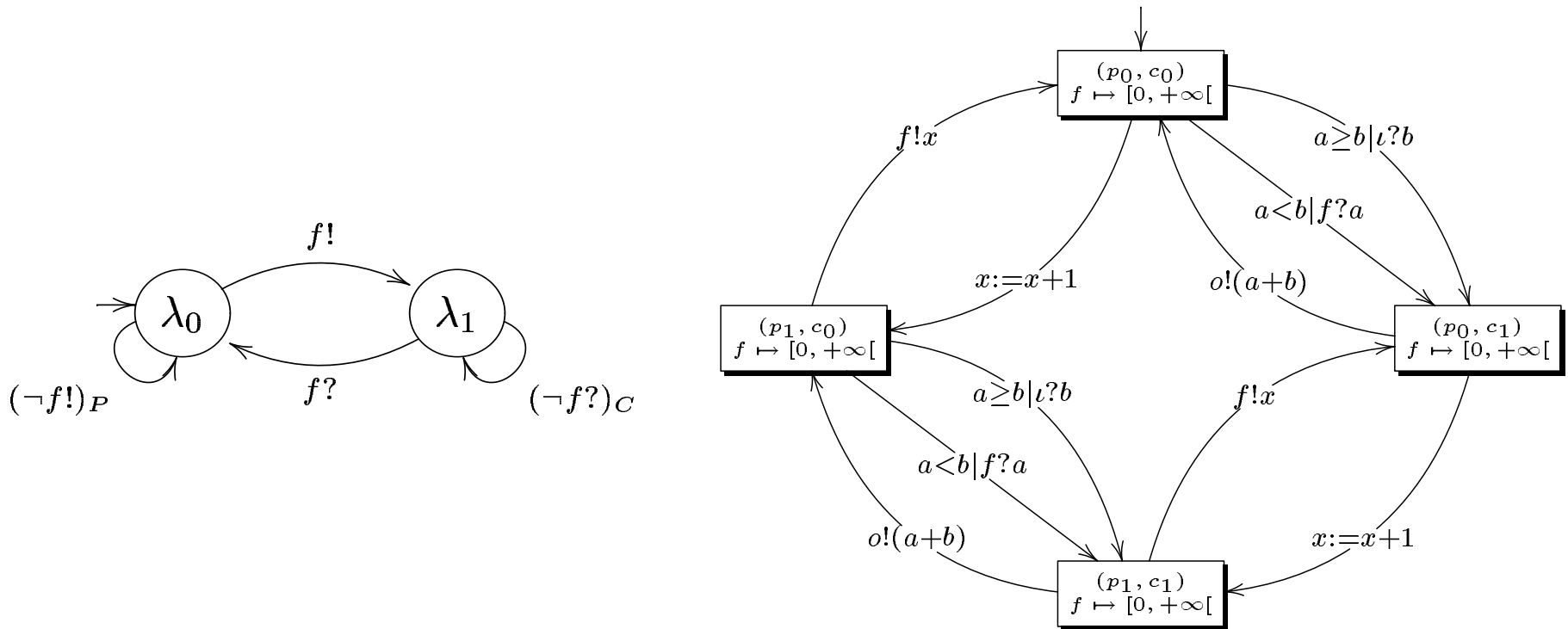

Enforcing constraint

- ▶ "Synchronized product" between AEG and constraints
- ▶ Example: $Aeg \parallel \Lambda_{FF}$

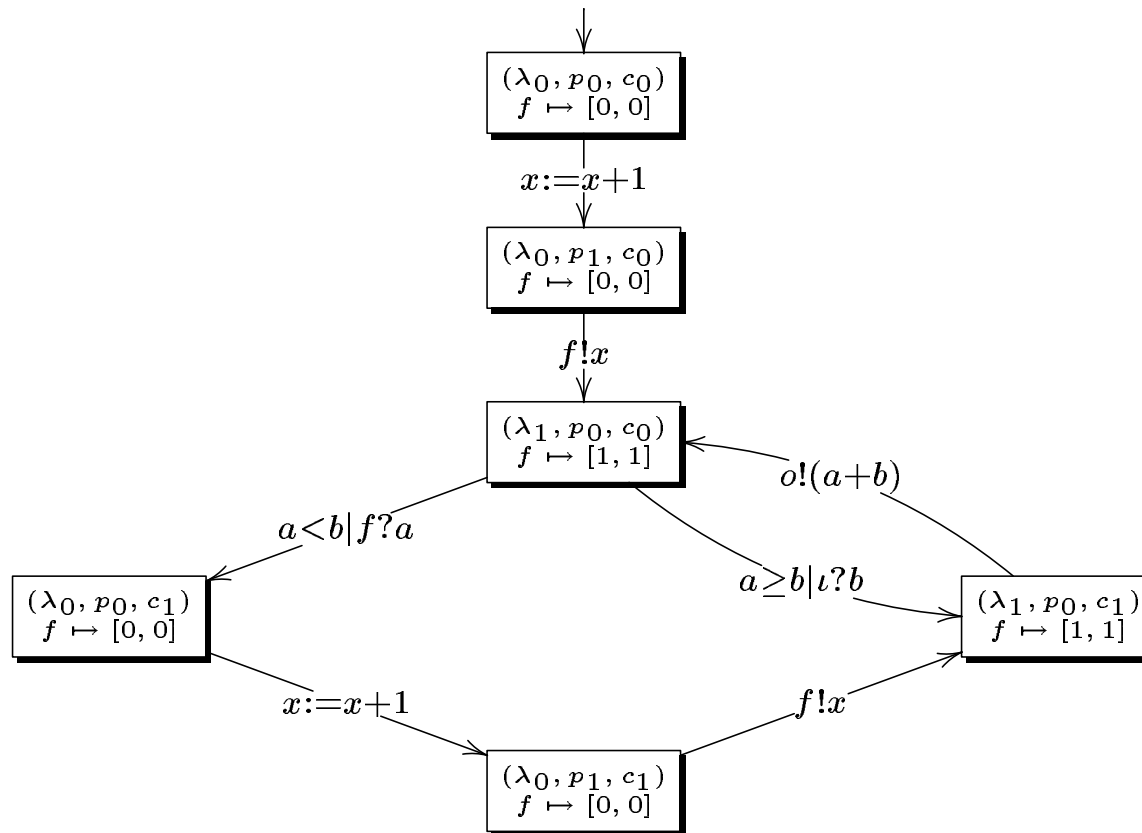

Overview

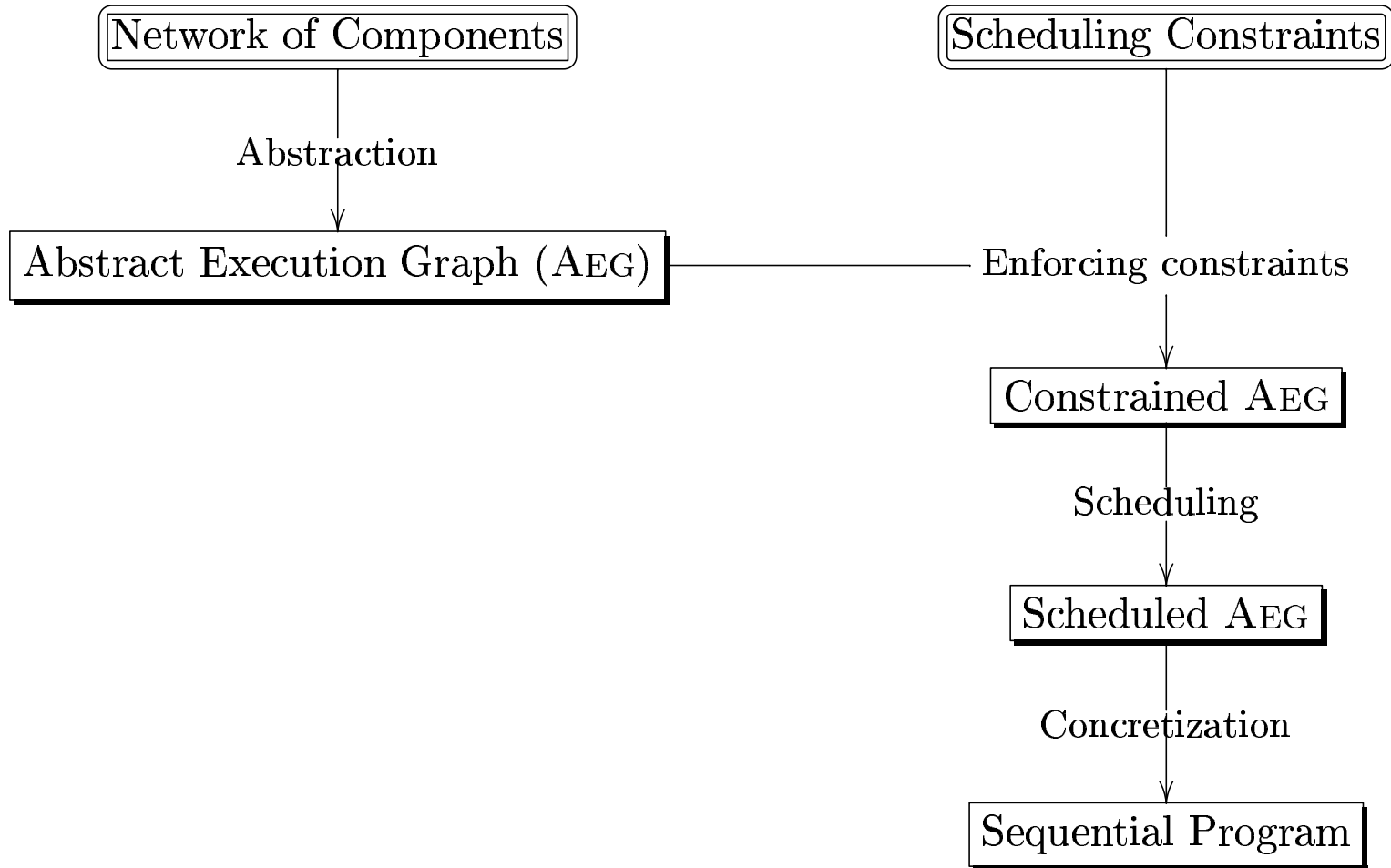

Completing scheduling

- ▶ Removing remaining choices by
 - ▶ Synchronized product with a standard sequential scheduler
 - ▶ Round-Robin expressed as a LTS:

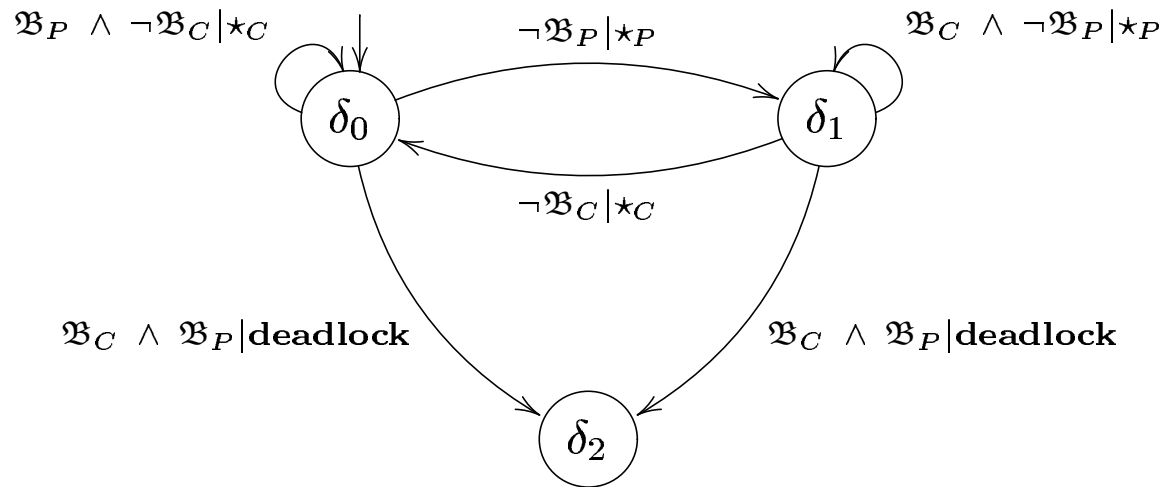

Overview

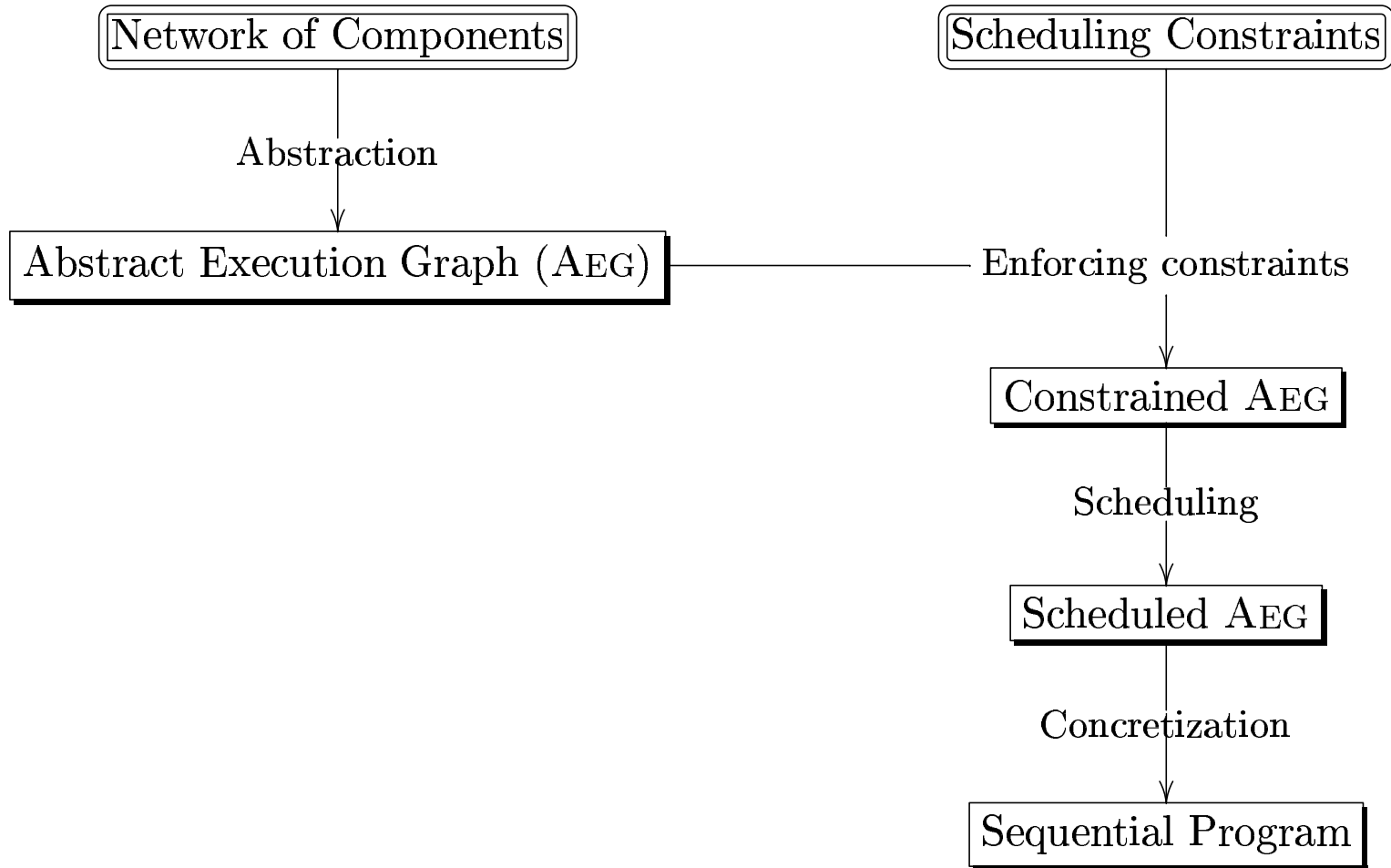

Concretization

$$F = \left\{ \begin{array}{l} f_0 : x := x + 1 \quad \rightsquigarrow \quad f_1; \\ f_1 : f!x \quad \rightsquigarrow \quad f_2; \\ f_2 : a < b \mid f?a \quad \rightsquigarrow \quad f_3; \\ f_2 : a \geq b \mid \iota?b \quad \rightsquigarrow \quad f_4; \\ f_3 : x := x + 1 \quad \rightsquigarrow \quad f_5; \\ f_4 : o!(a + b) \quad \rightsquigarrow \quad f_2; \\ f_5 : f!x \quad \rightsquigarrow \quad f_4 \end{array} \right\}$$

- ▶ then, replace internal IO instructions by assignments
 - ▶ $f!x \mapsto \text{tmp-f:=x}$ $f?x \mapsto \text{x:=tmp-f}$
- ▶ and optimize code

Related work

- ▶ Filter Fusion
- ▶ Functionnal programming
 - ▶ Listlessness and deforestation
- ▶ Embedded/reactive systems
 - ▶ Focus on scheduling for FIFO Channel
 - ▶ No user-defined scheduling strategy and/or no fusion

Conclusion

- ▶ Generic Framework to fusion components
 - ▶ Simple, formal, and efficient compilation of components
 - ▶ Highly parametric (choice of abstraction, scheduling constraints, and sequential scheduler)
- ▶ 3 extensions
 - ▶ Linguistic support
 - ▶ More precise abstraction
 - ▶ Instrumented product
- ▶ Future work
 - ▶ Complete correctness proof
 - ▶ Implement a prototype